



IDEC FA-XX COMMUNICATIONS REFERENCE





NOTICE

The products and services described in this manual are useful in a wide variety of applications. Therefore, the user and others responsible for applying the products and services described herein are responsible for determining their acceptability for each application. While efforts have been made to provide accurate information within this manual, Spectrum Controls assumes no responsibility for the accuracy, completeness or usefulness of the information contained herein.

Under no circumstances will Spectrum Controls be responsible or liable for any damages or losses, including indirect or consequential damages or losses, arising out of either the use of any information contained within this manual or the use of any product or service referenced herein.

No patent liability is assumed by Spectrum Controls with respect to the use of any of the information, products, circuits, programming or services referenced herein.

The information contained in this manual is subject to change without notice.

CAUTION

Spectrum Controls' devices contain electronic components which are susceptible to damage from electrostatic discharge. A static charge can accumulate on the surface of ordinary plastic wrapping or cushioning material. If any Spectrum Controls' device must be returned to Spectrum Controls, the following packaging instruction must be followed:

PREFERRED: Use the original packaging material as supplied by Spectrum Controls. Place the device inside the conductive plastic bag.

ACCEPTABLE: Wrap the device in some type of antistatic material. Antistatic plastic material can be identified by its pink color, and can be obtained in sheet or bag form.

UNACCEPTABLE: Do not use ordinary plastic film, foam, or styrene chips ("popcorn" or "peanuts"). These materials can accumulate charges in excess of 10,000 volts, resulting in possible damage to the Spectrum Controls electronic device.

Antistatic (metallized plastic) bags can be obtained from the following manufacturers:

3M Company	(800-328-1368)	Type 2100 bag
Static, Inc.	(800-782-8424)	8000 Series bag
Charles Water	(617-964-8370)	CP-303 bag



LIMITED WARRANTY

Spectrum Controls warrants that its products are free from defects in material and workmanship under normal use and service, as described in Spectrum Controls literature covering this product, for a period of 1 year. Spectrum Controls' obligations under this warranty are limited to replacing or repairing, at its option, at its factory or facility, any product which shall, in the applicable period after shipment, be returned to Spectrum Controls' facility, transportation charges prepaid, and which after examination is determined, to the satisfaction of Spectrum Controls, to be thus defective.

This warranty shall not apply to any such equipment which shall have been repaired or altered except by Spectrum Controls or which shall have been subject to misuse, neglect or accident. In no case shall Spectrum Controls' liability exceed the purchase price. The aforementioned provisions do not extend the original warranty period of any product which has either been repaired or replaced by Spectrum Controls.

Copyright and Trademark information

Copyright © 1998 Spectrum Controls, Inc.

SOI, SOI-SPS, and SOI-PRO are trademarks of Spectrum Controls, Inc.

IBM is a registered trademark of International Business Machines Corporation.

MS-DOS is a registered trademark of Microsoft Corporation.

IDEC and Micro 1 are registered trademarks of IDEC IZUMI Corporation.

All other trademarks belong to their respective owners.



CONTENTS

PREFACE	1
Who Should Use this Reference.....	1
Related Documents	2
CHAPTER 1: CABLING AND COMMUNICATION PORTS ...	3
Uploading and Downloading Application Programs	4
Connecting to the IDEC Processor.....	8
Outputting Printer Forms (SOI-260 only)	9
Accepting ASCII Input (SOI-260 only)	9
CHAPTER 2: PROGRAMMING	11
Supported IDEC Registers	12
Supported Data Formats.....	13
Screen Types and Supported Data Formats.....	19
Data Display and Entry Screen Parameters.....	20
Multiple Entry.....	25
IDEC-Specific Configuration Parameters	27
CHAPTER 3: TROUBLESHOOTING	29
CHAPTER 4: TERMINAL MODE	31
“Arcade” Entry of ASCII Characters	31
Direct ASCII Code Entry (SOI-260 only)	32



CHAPTER 5: SPECIAL OPERATIONS (P-A/D)	33
Point-Access/Display on the SOI-120	33
Point-Access/Display on the SOI-260	36
INDEX	39



PREFACE

Read this preface to familiarize yourself with the rest of this Reference. This preface covers:

- who should use this guide
- related documents

This Reference covers the information needed to use an SOI-120 or -260 operator interface product with an IDEC FA-series (FA-1J, -2, -2J, and -3S)^① or “Micro 1” programmable controller. The Reference contains the information you need to install, program, troubleshoot, and use your SOI.

Please read all the information in this reference before you install or use your SOI.

Who Should Use this Reference

Use this Reference if you design, install, program, or maintain a control system that uses an IDEC FA-series (FA-1J, -2, -2J, and -3S)^① or “Micro 1” programmable controller.

This reference assumes a full working knowledge of the relevant programmable controller.

You should have a basic understanding of computer products. If you do not, contact your local distributor for the proper training before using these products.

^① See “Chapter 2: Programming” for the register types supported.



Related Documents

The following table lists related documents that may help you as you install and use these products:

Publication Number	Title
0300050	SOI-260 Operator Interface User Manual
0300051	SOI-120 Operator Interface User Manual
0300054	SOI-SPS Programming Software Manual
0300063	Upload/Download Cable For SOI-120 and SOI-260

CHAPTER 1: CABLING AND COMMUNICATION PORTS

This chapter of the *IDEC FA-XX Communications Reference* covers the cabling needed to use the SOI-120's communications port (see Figure 1.1) and the SOI-260's communications port and optional printer port (see Figure 1.2).

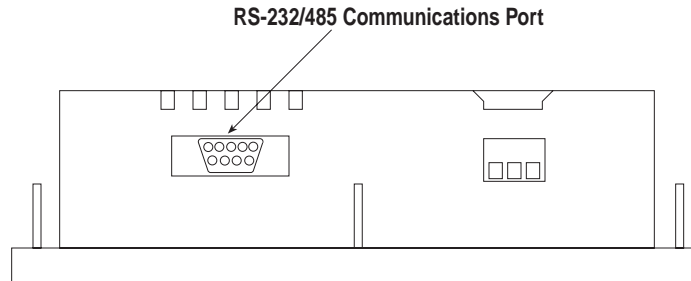

Figure 1.1 SOI-120 Communications Port.

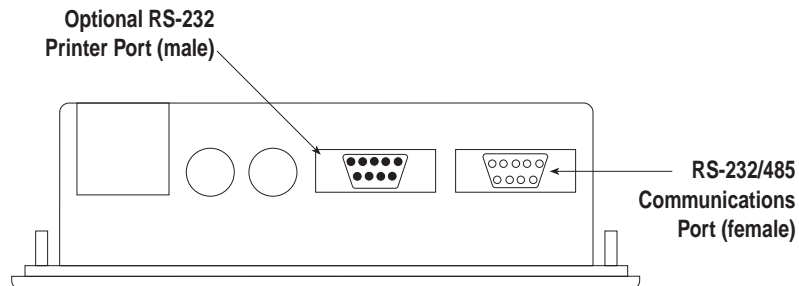

Figure 1.2 SOI-260 Communications Port and Optional Printer Port.



Use the communication ports to...

- upload or download application programs from a personal computer
- connect your SOI-120 or SOI-260 to the programmable controller

On the SOI-260, you can also use the optional RS-232 printer port to...

- output Printer Forms to a printer or other serial device, such as a large ASCII display unit
- accept data from an ASCII input device (such as a bar code scanner)

Uploading and Downloading Application Programs

On the SOI-260, you may use either the communications port or the optional printer port to upload or download application programs from a personal computer.

On the SOI-120, you must use the communications port.

The following subsections describe the cabling needed.

Upload/Download via Comm. Port (RS-232 communications selected)

Figures 1.3 and 1.4 show the cable pin connections (9-pin to 25-pin and 9-pin to 9-pin, respectively) when using the SOI-120's or SOI-260's communications port (RS-232 selected) to upload or download applications from a personal computer. The figures indicate the required connections when building your own cable.

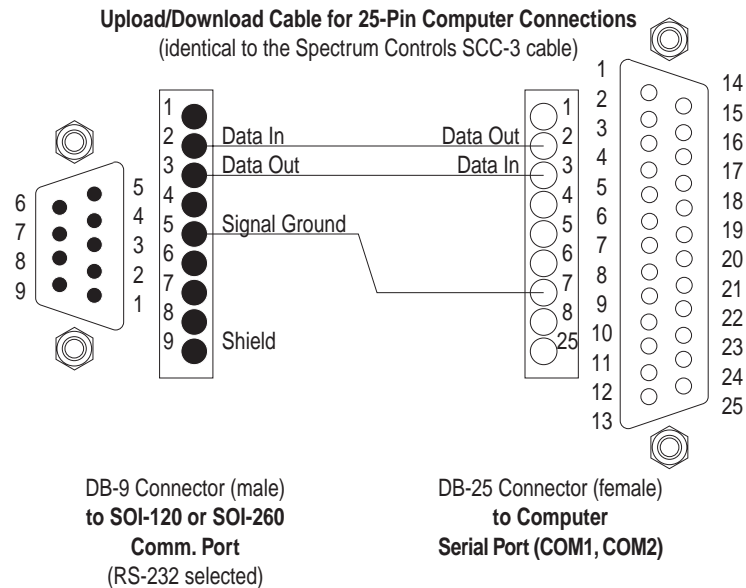

Figure 1.3 Upload/Download cable for 25-pin computer connections.

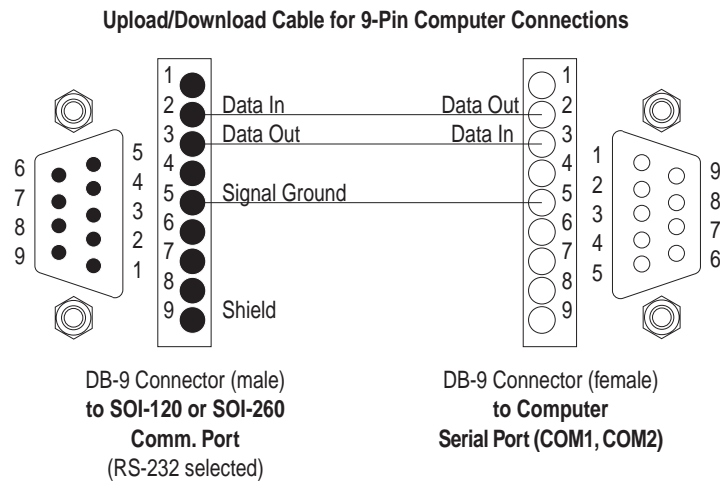

Figure 1.4 Upload/Download cable for 9-pin computer connections.

Upload/Download via Optional Printer Port (SOI-260 only)

Figures 1.5 and 1.6 show the cable pin connections (9-pin to 25-pin and 9-pin to 9-pin, respectively) when using the SOI-260's optional printer port to upload or download applications from a personal computer. The figures indicate the required connections when building your own cable.

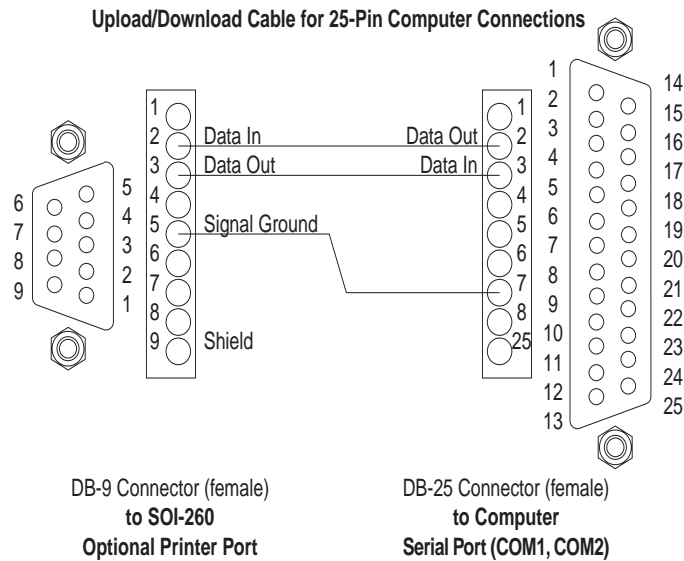

Figure 1.5 Upload/Download cable for 25-pin computer connections.

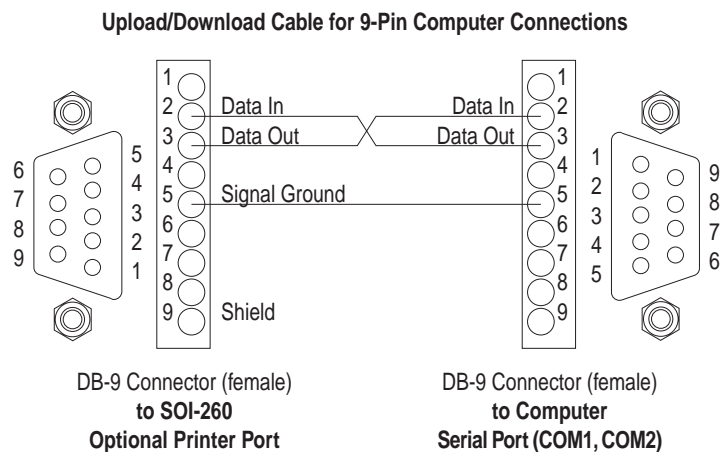

Figure 1.6 Upload/Download cable for 9-pin computer connections.

Upload/Download with the Spectrum Controls SCC-3 Cable

If you don't want to build your own cable, Spectrum Controls offers the SCC-3 cable for uploading and downloading application programs. The pin connections for the SCC-3 cable are identical to those shown in Figure 1.3. You may use the SCC-3 cable to connect the SOI-120's communications port or SOI-260's communications port or optional printer port to a personal computer. If your computer has a 9-pin communications port, you need a 25-to-9 pin adapter, shown in Figure 1.7. If you want to use the SOI-260's optional printer port for uploading and downloading applications, you also need a 9-pin female adapter, shown in Figure 1.8.

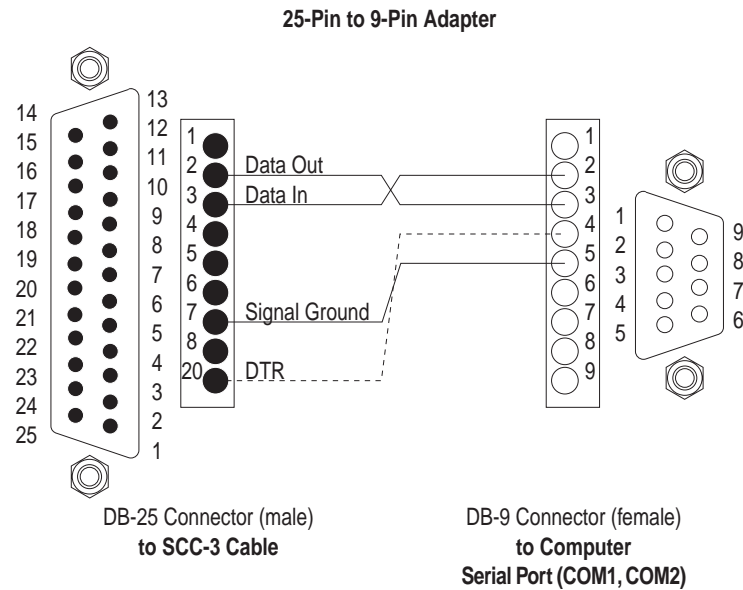

Figure 1.7 25-pin to 9-pin adapter.

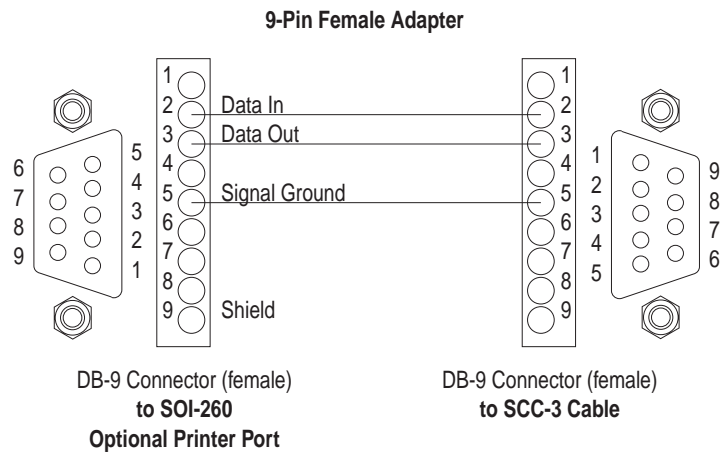

Figure 1.8 9-pin female adapter.



Connecting to the IDEC Processor

The SOI connects to the IDEC processor using either IDEC Link Adapter PF2-CLA (RS-232 communications selected) or IDEC Link Adapter PFJ-U21 (RS-485/422 communications selected), as shown in Figures 1.9 and 1.10.

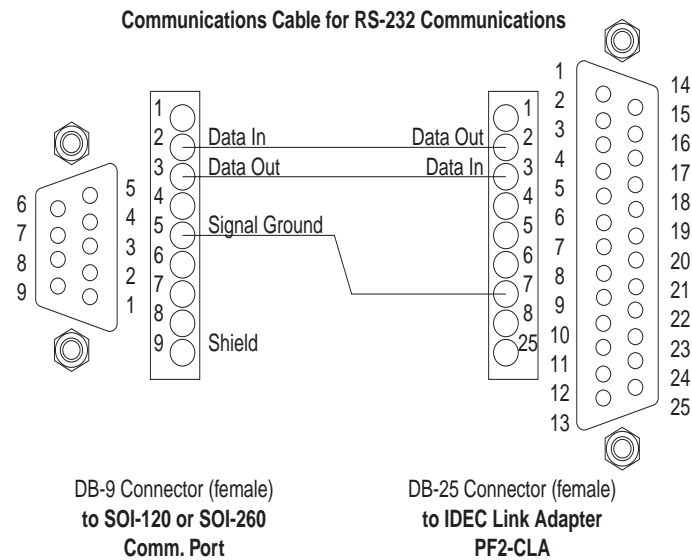

Figure 1.9 Communications cable for IDEC Link Adapter PF2-CLA.

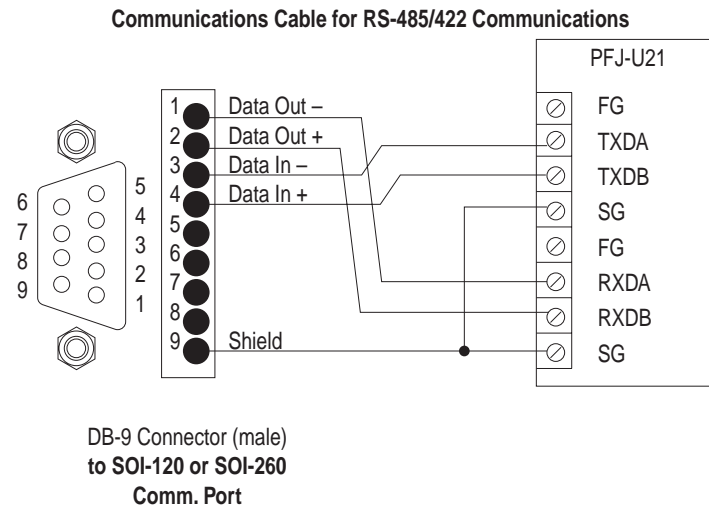

Figure 1.10 Communications cable for IDEC Link Adapter PFJ-U21.

Outputting Printer Forms (SOI-260 only)

You can use the SOI-260's optional printer port to output Printer Forms to a printer or other serial device, such as a large ASCII display unit. Printer forms are created in the SOI-SPS programming software and may include production reports, alarm messages, instructional text, etc.

Figure 1.11 illustrates the cabling needed.

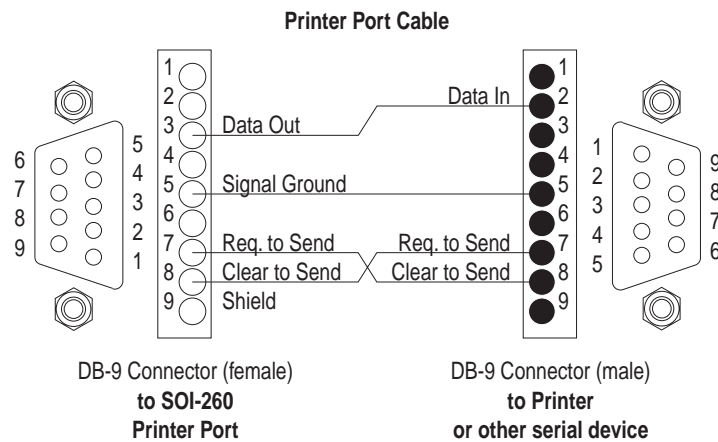

Figure 1.11 Printer port cable.

Accepting ASCII Input (SOI-260 only)

The SOI-260's optional RS-232 printer port may also be used to accept ASCII data from a variety of devices, including bar code scanners. When using a scanner to read a bar code, the ASCII data is entered directly from the device into a standard data entry screen (created using the SOI-SPS programming software) on the SOI-260.

Note: If the SOI-260 receives an odd number of characters from the scanner, the SOI-260 adds a Null character to create an even byte count. This facilitates word writes to the controller.

If keypad entry is enabled, the operator may also use the 0–9 and decimal point keys to enter numeric data into the data entry field. The SOI-260 writes data to the controller when any of the following occurs:

- the SOI-260 receives an ASCII carriage return character
- the operator presses the SOI-260's RETURN key
- the SOI-260 receives the maximum number of characters



For example, an operator can manually enter 2 characters and then scan a bar code containing 8 characters, with the last character being an ASCII carriage return. The SOI-260 then writes all 10 characters to the controller and moves to the next entry field.



CHAPTER 2: PROGRAMMING

This chapter of the *IDEC FA-XX Communications Reference* covers:

- supported IDEC processor registers
- supported SOI-120 and SOI-260 screen types and parameters
- multiple entry
- IDEC-specific configuration parameters



Supported IDEC Registers

The SOI-120 and SOI-260 support the following registers:

Register (Octal) ①	Size	Description	Read/Write Access
0-157	1bit	InputPoint	Read
200-357	1bit	OutputPoint	Read/Write
2000-2157	1bit	ExtendedInput	Read
2200-2357	1bit	ExtendedOutput	Read/Write
400-717	1bit	InternalRelays	Read/Write (714-717Readonly)
2400-2717	1bit	ExtendedIntRelays	Read/Write
R0-R127(Decimal)	1bit	ShiftRegister	Read/Write
D800-D899(Decimal)	16bits	DataRegister	Read/Write
D1500-D1799(Decimal)	16bits	ExtendedData Reg	Read/Write
C0-C47(Decimal)	16bits	Counter	Read ②
CP0-CP47(Decimal)	16bits	CounterPreset	Read/Write ② (Top2bitsreadonly. Entrylimits=0-9999dec or0-270Fhex)
T0-T79(Decimal)	16bits	Timer(100ms)	Read
T1100-T1179(Decimal)	16bits	Timer(10ms)	Read ③
TP0-TP79(Decimal)	16bits	TimerPreset(100ms)	Read/Write

① Use the register prefixes shown here when using the SOI-SPS programming software. See “Chapter 5: Special Operations” for the equivalent register prefixes when using the SOI’s Point-Access/Display feature (P-A/D).

② The FA-2J PLC only supports up to 46 Counter Presets. Counters 45 and 46 are reversible counters.

③ The FA-3S CP12 supports 10 ms Timers. the FA-2J does not.



Supported Data Formats

The data format selected for a particular programmable controller memory location must reflect the correct format for the data actually stored in that location. This is the only way you can ensure that correct, consistent information is displayed on the SOI-120 or SOI-260.

For example, selecting a 16-Bit Hex format for one location will display data in one way. Selecting a 16-Bit Signed Integer format for the same location will display the data in another way. It is important to understand each data format and its characteristics.

The following table lists all supported data formats and the ranges applicable to each:

Data Format	Range	Scalable to Engineering Units
Bit	0,1	No
16-bit signed integer	-32,768 to +32,767	Yes
16-bit unsigned integer	0 to +65,535	Yes
16-bit BCD	0 to 9,999	Yes
16-bit hexadecimal	0 to FFFF	No
32-bit unsigned integer	0 to +4,294,967,295	No
32-bit BCD	0 to +99,999,999	No
32-bit hexadecimal	0 to FFFF FFFF	No
ASCII display	0 to 20 characters	No
ASCII input	0 to 32 characters	No



The supported data formats are described below.

Bit

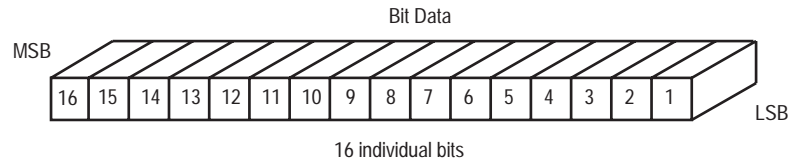

The programmable controller stores a binary (0 or 1) status for a bit location. The SOI will read a programmable controller bit location and determine whether the operational status of the bit is ON (1) or OFF (0). You can customize the text to be displayed on the screen of the SOI-120 or SOI-260 for either state of a specified bit. This text can be up to twenty characters.

For example, the OFF (0) state of a bit might display “Pump is OFF,” and the ON (1) state “Pump is ON.” SOI-SPS allocates enough screen characters for the longest of the two text strings. In this example, 12 characters would be allocated to display “Pump is OFF.”

Note: The fewer characters used, the less memory is required. In the example above, displaying "OFF" (given the appropriate context) conveys the same information in 3 characters as "Pump is OFF" does with 11 characters.

16-Bit Signed Integer

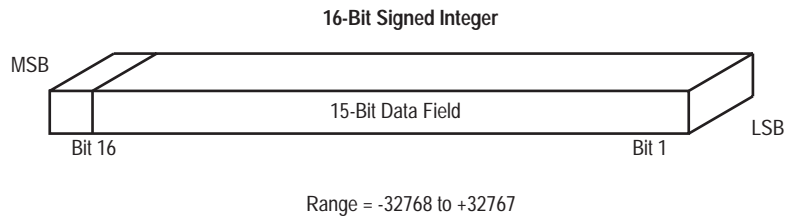

This data type displays a 16-bit register as a signed Integer (two’s complement) value. The 16th bit of the register is the sign bit and is set (1) for a negative and cleared (0) for a positive number. The 16-bit signed integer values have a range of -32768 to +32767.

Note: This data format may be scaled within the SOI-120 or SOI-260 to different engineering units.

16-Bit Unsigned Integer

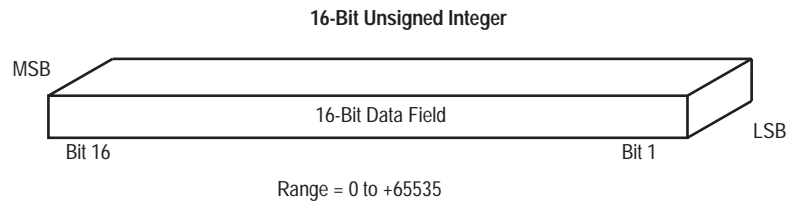

This data format displays a 16-bit register as an Unsigned Integer value. It represents a positive number by using the 16th bit as a data bit rather than a sign bit. The 16-bit Unsigned Integer values have a range of 0 to +65,535.

Note: This data format may also be scaled to different engineering units within the SOI-120 or SOI-260.

16-Bit Binary Coded Decimal

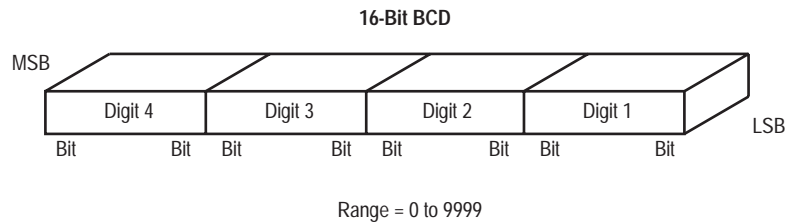

This data type displays a 16-bit register location as a 4-digit Binary Coded Decimal value. The range for the 16 bit BCD selection is 0 to +9999.

Note: This data format may also be scaled to different engineering units within the SOI-120 or SOI-260.



16-Bit Hexadecimal

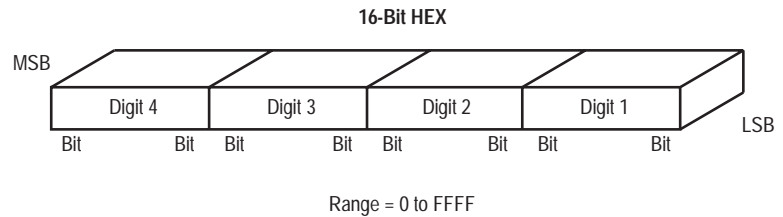

This data type displays a 16-bit register location as a 4-digit hexadecimal value. The range for the 16-bit Hex format is 0 to +FFFF. The Hexadecimal number system is defined as a base of 16 (0-9 and the characters A, B, C, D, E, F).

Note: This data format may not be scaled to different engineering units within the SOI-120 or SOI-260. It is used for display-only (non-entry) operations.

32-Bit Unsigned Integer

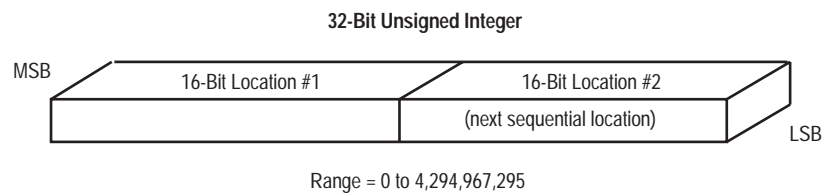

This data format displays data located in two consecutive 16-bit register locations as a 32-bit Unsigned Integer. It uses a memory register plus the next higher register to form the 32-bit location. The High data value is stored in the first register and the Low data value is stored in the next sequential register location. The range for the 32-bit unsigned Integer value is 0 to +4,294,967,295.

Note: This data format may not be scaled to different engineering units within the SOI-120 or SOI-260.



32-Bit Binary Coded Decimal

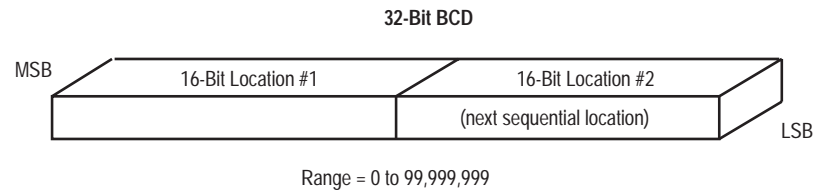

This data type displays two consecutive 16-bit register locations as a 32-bit BCD value. It uses a memory register plus the next higher register to form the 32 bit location. The range for the 32 bit BCD value is 0 to +99,999,999.

Note: This data format may not be scaled to different engineering units within the SOI-120 or SOI-260.

32-Bit Hexadecimal

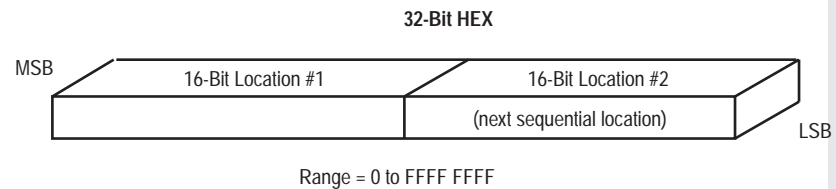

This data type displays two consecutive 16-bit register locations as a 32-bit Hex value. It uses a memory register plus the next higher register to form the 32-bit location. The range for the 32-bit HEX value is 0 to FFFF FFFF.

Note: This data format may not be scaled to different engineering units within the SOI-120 or SOI-260. This data format is used for display-only (non-entry) operations.

ASCII

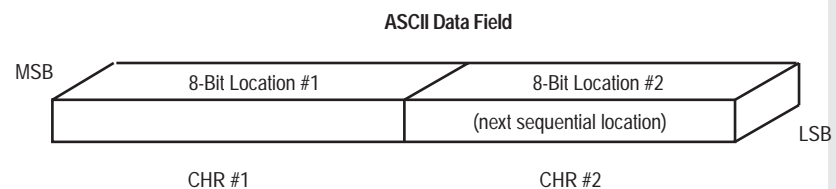



Each 16-bit location may contain two ASCII characters (1 byte each). By default, the most significant byte of the base address stores the first character, the least significant byte stores the second character, the first byte of the next sequential location stores the third character, and so on. The data held in this range of address locations is expected to be in ASCII data format.

Note: The ASCII data format is very useful for programmable controller applications reading ASCII data from bar code readers or data collection terminals.

Note: This data format may not be scaled to different engineering units within the SOI-120 or SOI-260.



Screen Types and Supported Data Formats

Each SOI Screen type may not support all data formats and point types. The following table lists each screen type and the associated data formats and register types supported:

Screen Type	Data Formats Supported	Register Types Supported
Display, Alarm, & Printer Form	Bit 16-Bit Signed Integer 16-Bit Unsigned Integer 16-Bit BCD 16-Bit HEX 32-Bit Unsigned Integer 32-Bit BCD 32-Bit HEX ASCII	All bit, T, TP, C, CP, D, R T, TP, C, CP, D T, TP, C, CP, D T, TP, C, CP, D T, TP, C, CP, D T, TP, C, CP, D T, TP, C, CP, D T, TP, C, CP, D T, TP, C, CP, D
Entry ①	Bit 16-Bit Signed Integer 16-Bit Unsigned Integer 16-Bit BCD 32-Bit Unsigned Integer 32-Bit BCD ASCII Input (SOI-260 only)	200–357, 2200–2357, 400–713, 2400–2717, R, TP, CP, D TP, CP, D TP, CP, D TP, CP, D TP, CP, D TP, CP, D TP, CP, D
Bargraph (SOI-260 only)	16-Bit Signed Integer 16-Bit BCD	T, TP, C, CP, D T, TP, C, CP, D
Recipe	16-Bit Signed Integer 16-Bit Unsigned Integer 16-Bit BCD 32-Bit Unsigned Integer 32-Bit BCD	TP, CP, D TP, CP, D TP, CP, D TP, CP, D TP, CP, D
Background Monitor (SOI-260 only)	Bit 16-Bit Signed Integer 16-Bit BCD	T, TP, C, CP, D T, TP, C, CP, D T, TP, C, CP, D

① If you create a Data Entry screen with the SOI-SPS programming software, and you try to create an entry field for a Timer (T) or Counter (C) register, the software assumes you meant a Timer Preset (TP) or Counter Preset (CP) register, since Timer and Counter registers are Read Only.



Data Display and Entry Screen Parameters

When programming Data Display and Data Entry fields and positioning them on an SOI-120 or SOI-260 screen, each field must be defined according to its programmable controller memory location (address), data format, and other data parameters specific to the data format selected.

You are prompted for the register definitions at the Control Window. Each register definition is somewhat different, depending on the data format selected and whether the data field is a Data Display or Data Entry field.

The tables in the following two subsections list the applicable data formats and the Control Window prompts associated with each.

Data Display Screens

The data format selections available for Data Display screens are listed below and their parameters described.

**Display Screen
Parameter for:**

Bit Data	Description
RegisterNumber	The programmable controller data location operand and address.
BitNumber	The Bit number if the register number designates a multiple bit location (a 16 bit data address, for example).
TextwhenBitisOFF(0)	The 20 character text description to be displayed when the bit is in an OFF (0) state
TextwhenBitisON(1)	The 20 character text description to be displayed when the bit is in an ON (1) state.



Display Screen	
Parameter for:	
16-Bit Unsigned Integer, 16-Bit Signed Integer & 16-Bit BCD Data	
	Description
RegisterNumber	The programmable controller data location operand and address.
Digits Right of Decimal	The number of digits to be placed to the right of the decimal.
Digits Left of Decimal	The number of digits to be placed to the left of the decimal.
Leave Place for Sign (Y or N)	Leave a one character place for the polarity sign (+ or -) when the data is displayed.
Show Leading Zeros (Y or N)	Display any zeros to the left of the data.
Minimum Register Value	The minimum data value of the programmable controller location.
Maximum Register Value	The maximum data value of the programmable controller location.
Minimum Displayed Value	The minimum data value to be displayed. This value is displayed when the data in the programmable controller location is equal to the minimum register value. See Maximum Displayed Value, below, for a description of scaling.
Maximum Displayed Value	The maximum data value to be displayed. This value is displayed when the data in the programmable controller location is equal to the maximum register value. The range defined by the Minimum Displayed Value and the Maximum Displayed Value is proportionally scaled to the range of the minimum and maximum register values. If both ranges are equal then the scaling ratio is 1:1.
Minimum Bar Value	(Bar Graph Only) The minimum value of data to be displayed in the Bar Graph. This value must be greater or equal to the Minimum Displayed Value.
Maximum Bar Value	(Bar Graph Only) The maximum value of data to be displayed in the Bar Graph. This value must be less than or equal to the Maximum Displayed Value. The Minimum and Maximum bar graph values may be used to display a particular range or window of an overall range (Minimum and Maximum Displayed Values).



**Display Screen
Parameter for:
32-Bit Unsigned Integer &
32-Bit BCD Data**

	Description
RegisterNumber	The programmable controller data location operand and address.
Digits Right of Decimal	The number of digits to be placed to the right of the decimal.
Digits Left of Decimal	The number of digits to be placed to the left of the decimal.
Show Leading Zeros (Y or N)	Display any zeros to the left of the data.

Note: For the 32-Bit BCD selections, scaling of data is not supported. The selected register number and the next higher sequential register number identify the locations defining the 32 bit data value.

**Display Screen
Parameter for:
16 -Bit HEX,
32-Bit HEX Data**

	Description
RegisterNumber	The programmable controller data location operand and address.

**Display Screen
Parameter for:
ASCII Data:**

	Description
RegisterNumber	The programmable controller data location operand and address.
CharacterCount	The number of characters (2 characters for each 16 bit data location) to be displayed, up to a maximum of 20 characters. The initial byte of the location identified by the register number is displayed first, then the second byte, the first byte of the next higher sequential location, and so on. To display 20 characters, a sequential block of ten 16 bit locations is read by the SOI.



Data Entry Screens

The data format selections available for Data Entry screens are listed below and their parameters described.

Entry Screen Parameter for: Bit Data	Description
RegisterNumber	The programmable controller data location operand and address.
BitNumber	The Bit number if the register number designates a multiple bit location (a 16 bit data address, for example). This selection is irrelevant if the register number refers to a Bit type address.
Input Data by Pressing 1/0 or Y/N? (Enter 1 or Y)	This parameter determines whether the operator will enter 1 or Y to set the defined bit location. If 1 is entered, 0 will clear the bit location. If Y is entered, N will clear the bit location.
Default Value? Z = No Default (Enter 1, 0, Y, N, Z)	This parameter defines the default value that is displayed at the data entry position of the SOI display. If a default value of Y is entered, a Y is displayed, and the operator is only required to press ENTER to set the bit location. An entry of Z defines no default value. If there is no default value programmed, and the operator presses the ENTER, no data is sent to the programmable controller.
Entry Screen Parameter for: 16-Bit Unsigned Integer, 16-Bit Signed Integer & 16-Bit BCD Data	Description
RegisterNumber	The programmable controller data location operand and address.
Digits Right of Decimal	The number of digits to be placed to the right of the decimal.
Digits Left of Decimal	The number of digits to be placed to the left of the decimal.
Leave Place for Sign (Y or N)	Leave a one character place for the polarity sign (+ or -) when the data is displayed.
Minimum Register Value	The minimum data value of the programmable controller location.



Maximum Register Value	The maximum data value of the programmable controller location.
Minimum Entry Value	The minimum data value to be entered. When this value is entered the minimum register value is entered to the defined programmable controller location. See Maximum Entry Value, below, for a description of scaling.
Maximum Entry Value	The maximum data value to be entered. When this value is entered the maximum register value is entered to the defined programmable controller location. The range defined by the minimum entry value and the maximum entry value is proportionally scaled to the range of the minimum and maximum register values. If both ranges are equal then the scaling ratio is 1:1.
Low User Input Limit	The minimum entry value that an operator may enter. This value must be within the minimum and maximum entry values. If a value lower than this limit is entered the SOL will display an "Input Error" screen displaying the minimum and maximum entry limits.
High User Input Limit	The maximum entry value that an operator may enter. This value must be within the minimum and maximum entry values. If a value higher than this limit is entered the SOL will display an "Input Error" screen displaying the minimum and maximum entry limits.
Default Value	This parameter defines a default value that is displayed at the entry location of the display. An entry of Z defines no default value.

**Entry Screen
Parameter for:
ASCII Data**

	Description
Register Number	The programmable controller data location operand and address.
Character Count	The number of characters (2 characters for each 16 bit data location) to be displayed, up to a maximum of 32 characters. The initial byte of the location identified by the register number is displayed first, then the second byte, the first byte of the next higher sequential location, and so on.



Entry Screen Parameter for: 32-Bit Unsigned Integer & 32-Bit BCD Data		Description
RegisterNumber		The programmable controller data location operand and address.
DigitsRightofDecimal		The number of digits to be placed to the right of the decimal.
DigitsLeftofDecimal		The number of digits to be placed to the left of the decimal.
LowUserInputLimit		The minimum entry value that an operator may enter. This value must be within the range of 0 to +99,999,999. If a value lower than this is entered, the SOI will display an "Input Error" screen displaying the minimum and maximum entry limits.
HighUserInputLimit		The maximum entry value that an operator may enter. This value must be within the range of 0 to +99,999,999. If a value higher than this is entered, the SOI will display an "Input Error" screen displaying the minimum and maximum entry limits.
DefaultValue		This parameter defines a default value that is displayed at the entry location of the display. An entry of Z defines no default.

Note: For the 32-Bit BCD selections, scaling of data is not supported. The defined register number and the next higher sequential number locations will define the data value.

Multiple Entry

The SOI-120 and SOI-260 with the IDEC FA-XX communications protocol can now accept and display multiple entries per screen. The recommended limits are 4 entries/displays per screen (in any combination: for example 3 entries & 1 display or 2 entries & 2 displays). The display is "live" unless you are in the middle of an entry.

Note: Depending on the speed of the programmable controller, the cursor may appear to flash erratically when moving from screen to screen or between entry fields on the current screen. This flashing is cosmetic only.



The following table describes how to use the keys with the multiple entry feature.

Key	Description
NEXT	Moves you to the next screen. Cursor will be at the first (top left) entry of each screen. If at end of a series of link screens, pressing "NEXT" moves the cursor between entries.
PREV	Moves you up the list of link screens. Cursor will be at the first (top left) at the entry of each screen. If at start of a series of link screens, "PREV" moves you between entries.
ENTER	Allows you to send data and move to next entry within an entry screen. If no data is entered, pressing ENTER moves you from one entry field to the next. Pressing ENTER does NOT move you to the next screen.

When using the function keys on the SOI-120 to jump to an entry screen with multiple entries, you must either press the "ENTER" key to go through all the entries defined, or you must press the "PREV" or "NEXT" key, before the SOI allows you to go back to the calling screen. That is, pressing "ENTER" at the last entry, "PREV", or "NEXT" brings you back to the calling screen (assuming auto-return is specified).

The following examples show how the multiple entry feature works:

EXAMPLE A

Example A has 4 screens linked one after the other. Screen 1 is the main menu screen. Screens 2–4 are entry screens. Each screen has 4 entries and 0 displays. Defaults are set to "NONE". If defaults were specified, pressing "ENTER" always sends the default value and then advances to the next entry position. The user must use the "PREV"/"NEXT" key to move up/down a series of linked screens.

Cursor movement is defined as follows: If you're at Screen 2, and the "ENTER" key is pressed several times, the cursor moves in the following order: (1), (2), (3) and (4) then back to (1).

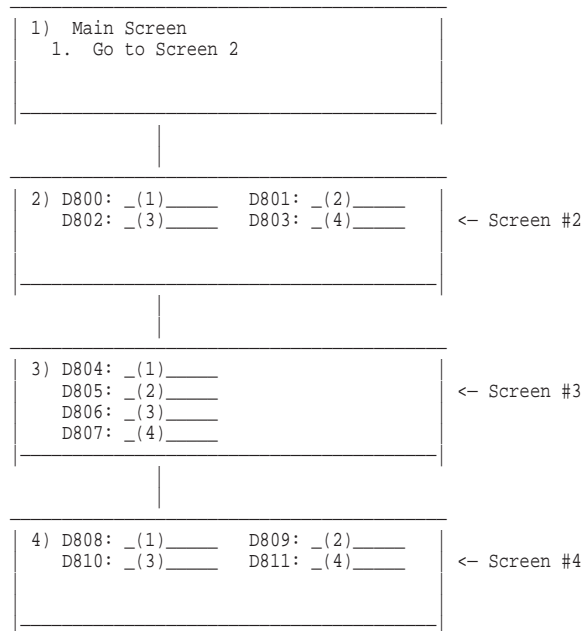

EXAMPLE B

Example B, below, shows screen 2 with 3 ASCII entries of field size 10. If you scan in (using a Bar Code Scanner) 20 characters, the first ten go into register D800, and the other 10 characters are discarded and the cursor moves to the next entry field. Pressing “ENTER” allows you to go to the the next entry field.

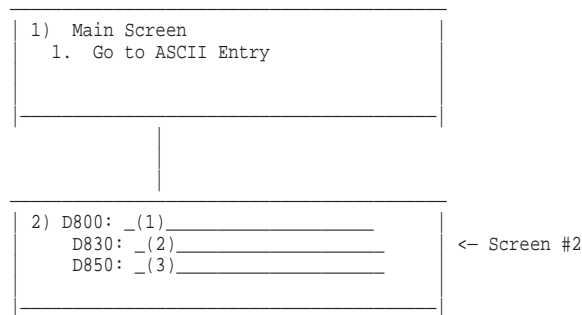

IDEC-Specific Configuration Parameters

This section describes the IDEC-specific PLC hardware parameters that the SOI-SPS programming software supports.

Note: Refer to the SOI-SPS programming software manual for complete details on programming and additional information regarding the parameters accessible from the SOI Configuration Data menu.



Select the PLC Hardware Parameters menu option from the SOI Configuration Data menu to modify the CPU Address, Communications Port Setup, or Advisor Update Rate.

The default **CPU Address** is: 1

The default **Communications Port Setup** is:

Baud Rate: 9600

Parity Even

The default **Advisor Update Rate** is: 2.00

Note: If you change the communication port parameters, you must also change the corresponding parameters at the CPU.

Note: You may also modify the communications port setup from the SOI. See “Chapter 5: Special Operations.(P-A/D)”

CHAPTER 3: TROUBLESHOOTING

This chapter of the *IEC FA-XX Communications Reference* provides solutions to possible problems with the SOI-120 and SOI-260 and their use with the IEC communications protocol.

Typically, any problems that occur involve communications between the SOI-120 or SOI-260 and the CPU. The communications software used to communicate with the CPU has passed critical compliance tests, usually eliminating the software as a possible source of a problem.

The only other possible sources are the cabling and the communication port parameters involved (baud rate, etc.). The communication parameters must be identical for both the SOI-120 or SOI-260 and the CPU. The cabling and the communications port parameters are always the first things to check.

Note: You can check the communications port parameters either from the SOI (see “Chapter 4: Special Operations (P-A/D)”) or from the SOI-SPS programming software (see “Chapter 2: Programming”).

If the cabling and communications parameters are correct, put the SOI-120 or SOI-260 in Self-Test mode to rule out any non-functioning features of the SOI.

Note: Refer to the SOI-120 or SOI-260 User’s Manual for detailed information about the Self-Test Mode.



The following screens appear on the SOI to indicate a problem:

**IDEC FA-XX
Establishing Comm**

Attempting to communicate to PLC. Action: None. Normal display when initiating communications with the PLC.

<PLC not found>

Communications not established with the PLC. This display is displayed after a 2 second interval of attempting to establish communications with the PLC. Action: Check cabling and communications parameters to verify that the PLC matches those of the SOI-120/260. Perform the Self Test function if the Comm port is suspected.

COMM ERR, Press "Y"

Communication with the PLC was lost after 16 attempts. Action: Check SOI-120/260 to PLC cabling. Check PLC operating conditions.

**COMM ERROR
PLC Error code: nn**

Received a Communication Error Code (nnn). Action: Refer to your PLC documentation for more information.

CHAPTER 4: TERMINAL MODE

Read this chapter of the *IDEC FA-XX Communications Reference* to become familiar with the SOI-120's and SOI-260's Terminal Mode of operation. This chapter covers:

- “arcade” entry of ASCII characters
- direct ASCII code entry (SOI-260 only)

In terminal mode, the SOI operates as a simple terminal: each key pressed on the SOI's keypad causes a character to be sent out the SOI's communications port. Displayable ASCII characters sent into its communications port are displayed on the SOI's screen.

“Arcade” Entry of ASCII Characters

The arcade entry method uses the PREV/NEXT keys to scroll through a set of ASCII characters.

If a character was selected via PREV/NEXT but not entered via ENTER and some other key is pressed, the new key press overrides the Arcade entry.

The following character set is provided:

```
‘ ABCDEFGHIJKLMNOPQRSTUVWXYZ=#?*:%,,$’
```

The above set includes a space, uppercase A through Z, the equal sign, the pound sign, the question mark, the asterisk, the colon, the percent sign, the forward slash, the comma, and the dollar sign.



Direct ASCII Code Entry (SOI-260 only)

The Direct ASCII code entry method allows the user to press the EXP key followed by a decimal value from 32 through 254 to enter an ASCII code directly.

CHAPTER 5: SPECIAL OPERATIONS (P-A/D)

After pressing “MODE” (the mode key) on the SOI-120 or “F” (the function key) on the SOI-260, one of the menu items is labelled “Special”. This item provides access to the Point-Access/Display (P-A/D) feature.

The P-A/D feature gives you access to all unrestricted programmable controller addresses. With this access, addresses may be displayed and/or modified. This feature is extremely useful in start-up or debugging sessions of programs or regular programmable controller operations.



CAUTION: The Point-Access/Display feature is a powerful tool. Its access should be restricted solely to authorized personnel. When using this feature, it is possible to change programmable controller data that may alter critical process control operations.

Note: After pressing “MODE” (SOI-120) or “F” (SOI-260), a Special Security Screen may be displayed (it has to be created with the SOI-SPS Programming Software). You must enter one of the three programmed security codes to continue to the Special Operations menu screen.

Point-Access/Display on the SOI-120

Figure 5.1 shows the Point-Access/Display screens and the key presses linking them:

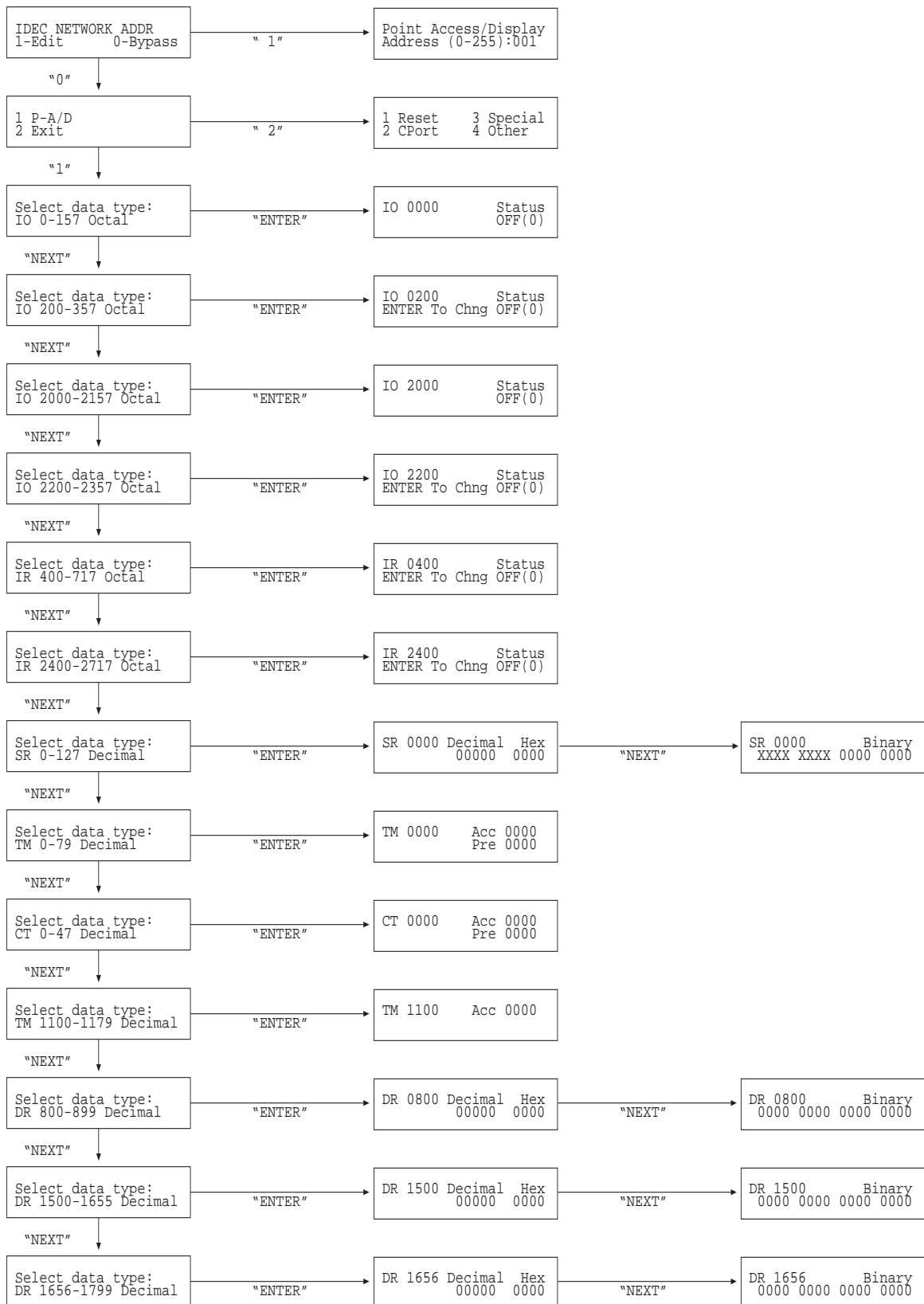

Figure 5.1 SOI-120 Point-Access/Display (P-A/D) screens



To display or modify programmable controller addresses from the SOI-120:

1. Press “MODE” (the mode key) on the SOI-120 keypad.
2. Select “Special” (item 3) from the menu that appears. If a Special Security Screen appears, enter any one of the programmed security codes.
3. Select “Bypass” (item 0), unless you want to Edit (item 1) the IDEC network address.
4. Select “P-A/D” (item 1).
5. Press “NEXT” until the data type you want to display or modify appears (see Table 5.1, and then press “↵” (the enter key).
6. Enter the address you want to display or modify and press “↵” (the enter key). Alternatively, you can press “F1” and “F2” to decrement and increment the address shown.

For 16-bit registers with read/write access, you can press “PREV” or “NEXT” to move you between the address and data fields so you can enter new data.

8. Press “↵” (the enter key) to load new data into the programmable controller. This new data is displayed immediately.

Note: At any point, pressing “MENU” returns you to the main menu.



Table 5.1 Supported IDEC Registers

Register (Octal) ①	Size	Description	Read/Write Access
IO 0–157	1 bit	Input Point	Read
IO 200–357	1 bit	Output Point	Read/Write
IO 2000–2157	1 bit	Extended Input	Read
IO 2200–2357	1 bit	Extended Output	Read/Write
IR 400–717	1 bit	Internal Relays	Read/Write
IR 2400–2717	1 bit	Extended Int Relays	Read/Write
SR 0–127 (Decimal)	1 bit √	Shift Register	Read/Write
DR 800–899 (Decimal)	16 bits	Data Register	Read/Write
DR 1500–1799 (Decimal)	16 bits	Extended Data Reg	Read/Write
CT 0–47 (Decimal)	16 bits	Counter	Read ②
CT 0–47 (Decimal)	16 bits	Counter Preset	Read/Write ② (Top 2 bits read only. Entry limit = 0–9999 dec or 0–270F hex)
TM 0–79 (Decimal)	16 bits	Timer (100 ms)	Read
TM 1100–1179 (Decimal)	16 bits	Timer (10 ms)	Read ③
TM 0–79 (Decimal)	16 bits	Timer Preset (100 ms)	Read/Write

① Use the register prefixes shown here (IO, IR, SR, DR, CT, and TM) when using the SOI's Point-Access/Display feature (P-A/D). See “Chapter 2: Programming” for the equivalent register prefixes when using the SOI-SPS programming software.

② The FA-2J PLC only supports up to 46 Counter Presets. Counters 45 and 46 are reversible counters.

③ The FA-3S CP12 supports 10 ms Timers. the FA-2J does not.

√ For your convenience, the P-A/D feature displays the first 7 SR locations above the selected SR location, in addition to the selected SR location itself (for a total of 8). The P-A/D feature also displays the Dec and Hex equivalents of those 8 bits. (In fact, if desired, you can enter values into the Dec field to change the selected SR location: an odd value sets the SR location to 1; an even value clears it to 0.)

Point-Access/Display on the SOI-260

Figure 5.2 shows the Point-Access/Display screens and the key presses linking them:

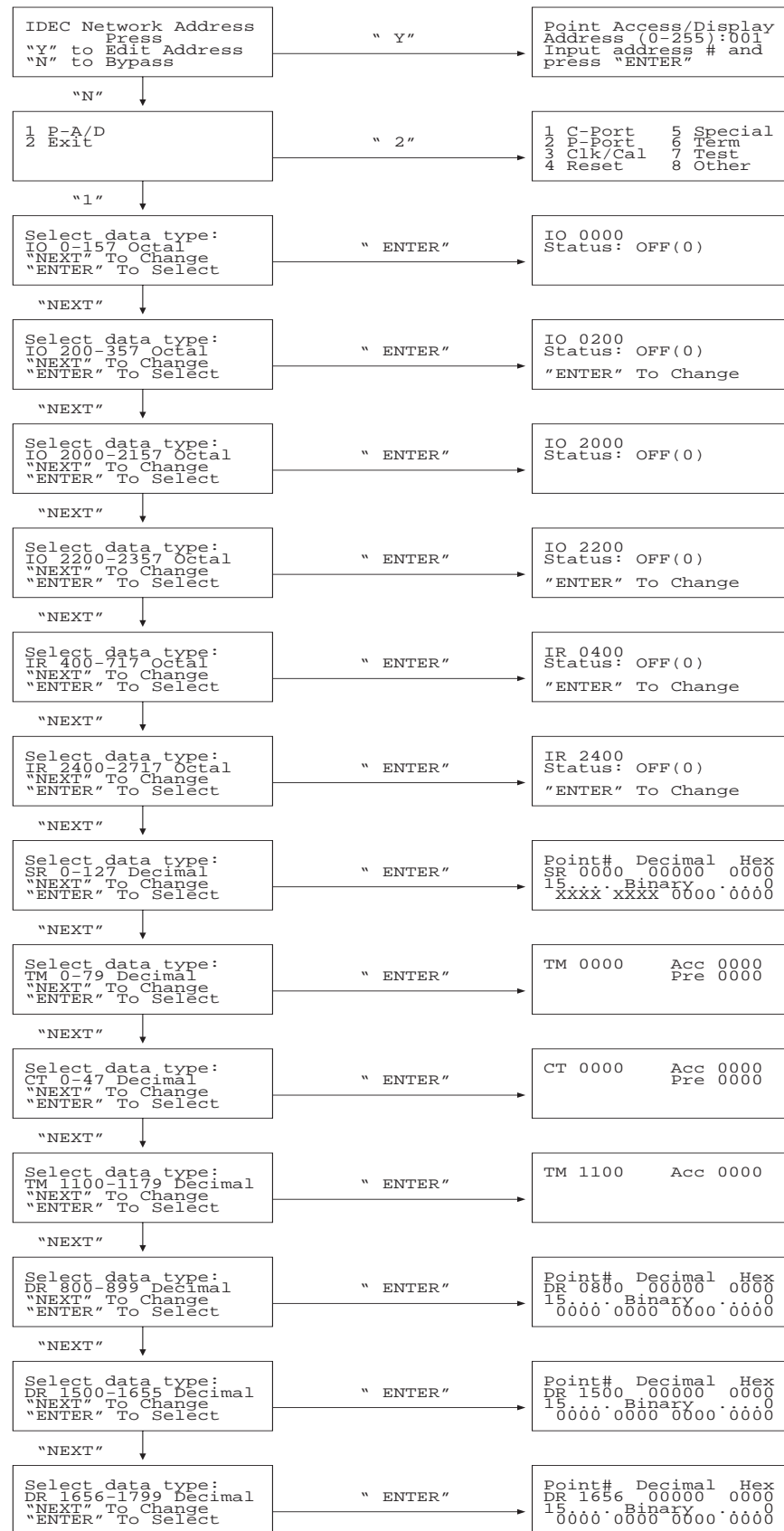

Figure 5.2 SOI-260 Point-Access/Display (P-A/D) screens



To display or modify programmable controller addresses from the SOI-260:

1. Press “F” (the function key) on the SOI-260 keypad.
2. Select “Special” (item 5) from the menu that appears. If a Special Security Screen appears, enter any one of the programmed security codes.
3. Select “Bypass” (Press “N”), unless you want to Edit (Press “Y”) the IDEC network address.
3. Press “1” to use the P-A/D function.
4. Press “PREV” or “NEXT” until the file type you want to display or modify appears (see Table 5.1), and press “↵” (the enter key).
5. Enter the address you want to display or modify and press “↵” (the enter key) to change the register value. Alternatively, you can press “N” and “Y” to decrement and increment the address shown.

For 16-bit registers with read/write access, you can press “PREV” or “NEXT” to move you between the address and data fields so you can enter new data.

7. Press “↵” (the enter key) to load the new data into the programmable controller. The new data that was loaded into the programmable controller is immediately displayed.

Note: At any point, pressing “MAIN MENU” returns you to the main menu.



INDEX

SYMBOLS

- 16-bit formats
 - BCD 15
 - Hex 16
 - signed integer 14
 - unsigned integer 15
- 32-bit formats
 - BCD 17
 - Hex 17
 - unsigned integer 16

A

- Adapters 7
- Addresses, accessing 33–36, 36–38
- Application programs, uploading/downloading 4
- Arcade entry 31
- ASCII
 - code entry 32
 - data input 9
 - display unit 9
 - format 17–18
 - input device 9

B

- Barcode scanner 9
- Baud rate 28
- BCD formats
 - 16-bit 15
 - 32-bit 17
- Binary Coded Decimal. *See* BCD formats
- Bit format 14

C

- Cabling 3

- Communication
 - cabling 3
 - ports 3
 - software 29–30
- Computer. *See* Programming computer
- Controller. *See* Network master computer

D

- Data
 - display 20–25
 - entry 20–25
 - formats supported 13–18, 19
- Data entry 31–32
- DeviceNet
 - port 8
- Display screen parameters 20–22
- Documentation 2
- Downloading applications
 - via optional printer port 5
 - via RS-232 communications port 4

E

- Electrostatic damage i
- Entering data 31–32
- Entry screen parameters 23–25
- Error messages 30

F

- Fault messages 30
- File types supported 12
- Formats supported 13–18, 19
- Function key. *See* F key



H

Hex formats

16-bit 16

32-bit 17

Host controller. *See* Network master computer

I

Input

buffer size 12

file 12

Integer formats

16-bit signed 14

16-bit unsigned 15

32-bit unsigned 16

L

Liability i

O

Output

buffer size 12

file 12

P

Packaging instructions i

Password 33

Personal computer. *See* Programming computer

Pin connections 3

Point access/display 33, 33–36, 36–38

Ports 3

Printer forms, outputting 9

Printer port 9

Programming 11–28

Programs, uploading/downloading 4

Publications 2

S

SCC-3 cable 6

Screen. *See* Display

Screens

data

display 20–22

entry 23–25

security 33

types supported 19

Security code 33

Security screen 33

Special Operations 33–38

Special security screen 33

T

Troubleshooting 29–30

U

Uploading applications

via optional printer port 5

via RS-232 communications port 4

Uploading/downloading applications 4

W

Warranty information ii

Copyright © 1998 Spectrum Controls, Inc. All rights reserved.
Specifications subject to change without notice. Printed in U.S.A.
Publication 0300158-02 Rev. B.0 April 1998

Corporate Headquarters

Spectrum Controls, Inc.
P.O. Box 5533 • Bellevue, Washington 98006
Fax: (425) 641-9473 • Tel: (425) 746-9481

Northeastern U.S.A. Sales Office

Spectrum Controls, Inc.
48945 Van Dyke, 4B • Utica, Michigan 48317
Fax: (586) 731-2715 • Tel: (586) 731-2397

Southeastern U.S.A. Sales Office

Spectrum Controls, Inc.
8860 Saddle Trail • Ball Ground, Georgia 30107
Fax: (678) 455-4615 • Tel: (678) 455-4640

Web Site: <http://www.spectrumcontrols.com>
E-mail: spectrum@spectrumcontrols.com

