Preface

Read this preface to familiarize yourself with the rest of the owner's guide. This preface covers:

- who should use this guide
- what this guide covers
- related Allen-Bradley documents
- terms & abbreviations you should know

Who Should Use This Guide

Use this guide if you design, install, program, or maintain a control system that uses Allen-Bradley Small Logic Controllers.

You should have a basic understanding of SLC 500 products. You should also understand electronic process control and the ladder program instructions required to generate the electronic signals that control your application. If you do not, contact your local Allen-Bradley representative for the proper training before using these products.

What This Guide Covers

This guide covers the 1746sc-NO8i and 1746sc-NO8v analog output modules. It contains the information you need to install, wire, use, and maintain these modules. It also provides diagnostic and troubleshooting help should the need arise.

Related Allen-Bradley Documents

Table 1 lists several Allen-Bradley documents that may help you as you use these products.

Table 1. Related Allen-Bradley documents

Allen-Bradley Doc. No.	Title
1747-2.30	SLC 500 System Overview
SGL-1.1	Application Considerations for Solid State Controls
1770-4.1	Allen-Bradley Programmable Controller Grounding and Wiring Guidelines
1747-6.2	Installation & Operation Manual for Modular Hardware Style Programmable Controllers
1747-NI001	Installation & Operation Manual for Fixed Hardware Style Programmable Controllers
1747-6.15	Allen-Bradley SLC 500 Instruction Set Reference Manual
ABT-1747-TSG001	SLC 500 Software Programmers's Quick Reference Guide
1747-NP002	Allen-Bradley HHT (Hand-Held Terminal) User Manual
1747-NM009	Getting Started Guide for HHT (Hand-Held Terminal)
SD499	Allen-Bradley Publication Index
AG-7.1	Allen-Bradley Industrial Automation Glossary

To obtain a copy of any of the Allen-Bradley documents listed, contact your local Allen-Bradley office or distributor.

Terms & Abbreviations You Should Know

You should understand the following terms and abbreviations before using this guide. For the definitions of terms not listed here, refer to *Allen-Bradley's Industrial Automation Glossary*, Publication AG-7.1

Channel – Refers to one of the sets of signal interfaces available on a module's terminal block.

Channel update time – For analog outputs, the time required for the channel to convert the data received from the processor to analog output signals at the terminals.

Chassis – See rack.

Configuration word – Contains the channel configuration information needed by the module to configure and operate each channel. Information is written to the configuration word through the logic supplied in your ladder program.

D/A – Refers to digital-to-analog conversion. The conversion produces an analog output signal whose magnitude is proportional to the digital value.

Data scaling - The data format that you select to define the logical increments of the channel data word.

Data word – A 16-bit integer that represents the value of the analog output channel. The channel data word is valid only when the channel is enabled and there are no channel errors.

LSB (least significant bit) – The bit that represents the smallest value within a string of bits. The “weight” of this value is defined as the full-scale range divided by the resolution.

Module ID code – A unique number associated with each 1746 I/O module. The code defines for the processor the type of I/O or specialty module residing in a specific slot in the 1746 chassis.

Module update time – See channel update time.

Overall accuracy – The worst-case deviation of the signal over the full range, expressed in percent of full scale.

Rack – A hardware assembly that houses devices such as I/O modules, adapter modules, processor modules, and power supplies.

Repeatability – The closeness of agreement among repeated measurements of the same variable under the same conditions.

Resolution – The smallest detectable change in a measurement, typically expressed in engineering units (e.g. microseconds) or as a number of bits. For example, a 16-bit system has 65536 possible output states. It can therefore measure 1 part in 65536. See also effective resolution.

Status word – Contains status information about the channel’s current configuration and operational state. You can use this information in your ladder program to determine whether the channel data word is valid.

Step response time – The time required for the output signal to reach 95% of its expected, final value, given a full-scale step change in the output data word.

Contents

Preface	v
Who Should Use This Guide	v
What This Guide Covers	v
Related Allen-Bradley Documents	v
Table 1. Related Allen-Bradley documents	vi
Terms & Abbreviations You Should Know	vi
Overview And Specifications.....	1
General Features And Benefits	1
Detailed Specifications	2
Table 2. Electrical specifications—module	2
Table 3. Electrical specifications—outputs	3
Table 4. Physical specifications	3
Table 5. Environmental specifications	4
Installing And Wiring Your Module	5
Avoiding Electrostatic Damage	6
Determining Power Requirements	6
Setting The Jumper J4	7
Selecting A Rack Slot	8
Inserting Your Module Into The Rack	8
Wiring Your Module	10
Labeling And Re-Installing The Terminal Block (if it is removed)	12
Things To Consider Before Using Your Module	13
How The Processor Communicates With Your Module	13
Channel Update Time	13
Your Module's Response To Slot Disabling	14
Channel Configuration, Data, and Status	15
Entering Your Module's ID Code	15
Output Image	16
Input Image	18
Configuring Each Output Channel	19
Set Optional Feature Values (Class 3 Only)	22
Setting The Output Data Words (Class 3 Only)	22
Optional Features - (Class 3 Only)	23
User-Defined Scale	23
Output Clamping	25
Set Limit Alarm Values	26
Set Ramping / Rate Limiting Values	27
Set Preset Fault Value	28
Channel's Configuration And Status (Class 1 and 3)	31
Chanel Input Status Word 2 (Class 3 Only)	34
Ladder Logic Sample	36

Testing Your Module	37
Inspecting Your Module	37
Disconnecting Prime Movers	38
Powering Up	38
Interpreting The LED Indicators	39
Interpreting I/O Error Codes	40
Troubleshooting	40
Maintaining Your Module And Ensuring Safety	41
Preventive Maintenance	41
Safety Considerations	41
Declaration of Conformity	xxxvii

Overview And Specifications

The 1746sc-NO8i provides eight channels of current outputs, while the 1746sc-NO8v provides eight channels of voltage outputs. In both modules, the current or voltage ranges are independently configurable for each channel. These modules also provide new, advanced features to make your control systems more dependable and flexible.

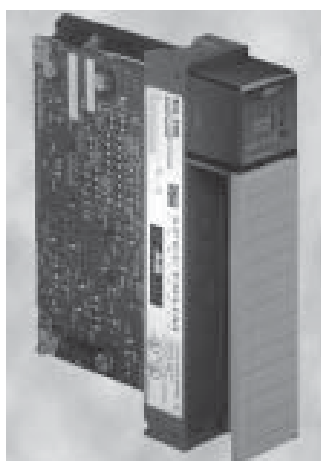

Read this chapter to familiarize yourself further with your isolated analog module (shown above). This chapter covers:

- general features and benefits
- detailed specifications

General Features And Benefits

Increased System Accuracy and Reliability

Both modules provide 8 output channels with a high *usable* resolution. They also provide 500 Vdc field-wiring-to-backplane isolation to protect the processor and rack. These modules maintain their accuracy with fluctuating ambient temperatures, which is important for crowded control cabinets.

Reduced System Costs

Several low-density modules may be replaced with one eight channel module. They also provide a single-slot solution for applications requiring up to eight outputs, so you don't have to buy more I/O than you need. Your ladder logic is simplified as the module provides channel ramping, limit alarms, output clamping, and various data scaling options.

State-of-the-Art Performance

These modules incorporate proprietary Allen-Bradley technology, so they operate and perform like the latest Allen-Bradley products. They also provide 16-bits of resolution, user-programmable range settings, requires no field calibration, software configuration, programmable output limits, and programmable safe states in case of a fault.

Detailed Specifications

Table 2. Electrical specifications—module

Backplane Current Consumption (maximum)		
1746sc-NO8i	120 mA @ 5 Vdc	
	250 mA @ 24 Vdc	
1746sc-NO8v	120 mA @ 5 Vdc	
	160 mA @ 24 Vdc	
Optional External 24V supply	+24V +/-10%	
Backplane Power Consumption (typical)	5.6 W	
Number Of Channels	8 single-ended	
I/O Chassis Location	Any 1746 I/O module slot except slot 0	
A/D Conversion Method	Sigma-Delta	
Calibration	Factory calibrated	
Opto-Electrical Isolation	500 Vdc field wiring-to-backplane	
Module ID Code		
1746sc-NO8i	3527	Class 1
	12727	Class 3
1746sc-NO8v	3528	Class 1
	12728	Class 3
Thermal Dissipation	6.6 W	

Table 3. Electrical specifications—outputs

Output Current Ranges—NO8i (selectable for each channel)	4 to 20 mA 0 to 20 mA 0 to 21 mA 0 to 21.5 mA
Output Voltage Ranges—NO8v only (selectable for each channel)	-10 to +10 Vdc -10.25 to +10.25 Vdc 0 to 10 Vdc 0 to 5 Vdc 1 to 5 Vdc
SLC Communication Formats (selectable for each channel)	Scaled engineering units Scaled for PID Proportional counts 1746-NO4 format User-defined scale
Output Impedance Current Outputs—NO8i Voltage Outputs—NO8v	Greater than 1 Mohm Less than 1.0 ohm
Load Range Current Outputs—NO8i Voltage Outputs—NO8v	0 to 500 ohm 1Kohm and greater
Max. Current, Voltage Mode—NO8v	10 mA
Output Step Response Time	1 ms (0–95% of full scale)
Channel Update Time (typical) Class 1 Class 3	5ms to update all 8 channels 10ms to update all 8 channels
Output Resolution Current Outputs—NO8i Voltage Outputs—NO8v	16-bit 366 nA/count 320 μ V/count
Overall Accuracy Current Outputs—NO8i Voltage Outputs—NO8v	0.1% of full scale @ 25 °C 0.2% of full scale @ 60 °C 0.1% of full scale @ 25 °C 0.2% of full scale @ 60 °C

Table 4. Physical specifications

LED Indicators	Eight green channel status indicators, one for each channel One green module status indicator
Recommended Cable	Belden 8761 (shielded, twisted-pair) or equivalent
Wire Size (maximum)	Two 14–24 AWG wire per terminal
Terminal Block	Removable (supplied)

Table 5. Environmental specifications

Operating Temperature	0 to 60 °C (32 to 140 °F)
Storage Temperature	-40 to 85 °C (-40 to 185 °F)
Relative Humidity	5 to 95% non-condensing
Certifications	UL/CUL and CE
Hazardous Environment Classifications	Class I Division 2 Groups ABCD

Installing And Wiring Your Module

Read this chapter to install and wire your module. This chapter covers:

- avoiding electrostatic damage
- determining power requirements
- setting the external power jumper
- selecting a rack slot
- inserting your module into the rack
- wiring your module

Note that although your module has a jumper in the center of its printed circuit board, this jumper is for the manufacturer's use only. Also, your module was calibrated by the manufacturer, so you don't need to perform this task.

Important - For UL and CUL compliance, power and input/output (I/O) wiring must be in accordance with Class I, Division 2, wiring methods [Article 501-4 (b) of the National Electrical Code, NFPA 70] and in accordance with the authority having jurisdiction. Also, you must observe the warnings shown below. Failure to observe these warnings can cause personal injury.



WARNING

EXPLOSION HAZARD

Substitution of components may impair suitability for Class I, Division 2;

When in hazardous locations, turn off power before replacing or wiring modules;

Do not disconnect equipment unless power has been switched off or the area is known to be non-hazardous.

The following documents contain information that may help you as you install and wire your module:

- *National Electrical Code*, published by the National Fire Protection Association of Boston, MA
- IEEE Standard 518-1977, *Guide for the Installation of Electrical Equipment to Minimize Electrical Noise Inputs to Controllers from External Sources*
- IEEE Standard 142-1982, *Recommended Practices for Grounding of Industrial and Commercial Power Systems*
- *Noise Reduction Techniques in Electronic Systems*, by Henry W. Ott; published by Wiley-Interscience of New York in 1976

Avoiding Electrostatic Damage

Guard against electrostatic damage by observing the following precautions:



CAUTION

ELECTROSTATICALLY SENSITIVE COMPONENTS

- Before handling the module, touch a grounded object to rid yourself of electrostatic charge.
- When handling the module, wear an approved wrist strap grounding device.
- Handle the module from the front, away from the backplane connector. Do not touch backplane connector pins.
- Keep the module in its static-shield container when not in use or during shipment.

Failure to observe these precautions can degrade the module's performance or cause permanent damage.

Determining Power Requirements

The backplane of the SLC 500 system can provide both 5 Vdc and 24 Vdc power. The following table shows the maximum current consumed by your module when using these power sources:

Table 6. Backplane current consumed

Catalog Number	5 Vdc	24 Vdc*	
		w/o ext. supply	w/ ext. supply
1746-sc-NO8i	120mA	250mA	0mA
1746sc-NO8v	120mA	160mA	0mA

* The 1746sc-NO8i and 1746sc-NO8v output modules can use an external 24 Vdc power supply to reduce backplane loading. To use an external 24 Vdc power supply, you must set your module's jumper J4 as indicated in the following subsection. To comply with the U.L. regulation the external supply must be rated N.E.C. Class 2.

Use Table 6 to calculate the total load on the system power supply. For more information, see the Allen-Bradley system *Installation and Operation Manual*.

Setting The Jumper J4

The 1746sc-NO8i and 1746sc-NO8v output modules have an external 24 Vdc power jumper, J4, giving you the option of using an external power supply:

- With the jumper in the **1-2 Shorted** position, the module draws all its power from the backplane of the SLC system.

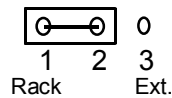

- With the jumper in the **2-3 Shorted** position, the module draws its 24 Vdc power from an external power source; however, the module still draws its 5 Vdc power from the backplane.

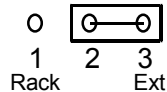

The jumper, J4, is located in the bottom right corner of the module's circuit board next to the power supply.

Note: Before setting J4 all system power must be turned off. This includes the rack power as well as the optional 24V external supply.

Note: If the module is configured to use an external +24V supply, the supply must be turned on for the module to operate. If the external +24V supply is turned off, the module's outputs will be turned off, and the module's processor will be reset until power is restored. The module's LEDs will blink the 24v failure blink code. See the error blink code descriptions in the troubleshooting section of this manual

Selecting A Rack Slot

Three factors determine where you should install your module in the rack: ambient temperature, electrical noise and Class 1/3 operation. When selecting a slot for your module, try to position your module:

- in a rack close to the bottom of the enclosure (where the air is cooler)
- away from modules that generate significant heat, such as 32-point input/output modules
- in a slot away from ac or high-voltage dc modules, hard contact switches, relays, and ac motor drives
- to use the advanced features of Class 3 operation the module must be located in the local rack. A 5/02 or above CPU must be used.
- away from the rack power supply (if using a modular system)

Remember that in a modular system, the processor always occupies the first slot of the rack.

Inserting Your Module Into The Rack



CAUTION

POSSIBLE EQUIPMENT OPERATION

Before installing or removing your module, always disconnect power from the SLC 500 system and from any other source to the module (in other words, don't "hot swap" your module), and disconnect any devices wired to the module.

Failure to observe this precaution can cause unintended equipment operation and damage.

When inserting your module into the rack, you do not need to remove the supplied 18-position terminal block from the module. If, however, you do remove the terminal block and use the write-on label to identify your module's location.

To remove the terminal block, unscrew the two retaining screws at the top and bottom of the terminal block, and using a screwdriver or needle-nose pliers, carefully pry the terminal block loose.

To insert your module into the rack, follow these steps:

1. Align the circuit board of your module with the card guides at the top and bottom of the chassis.

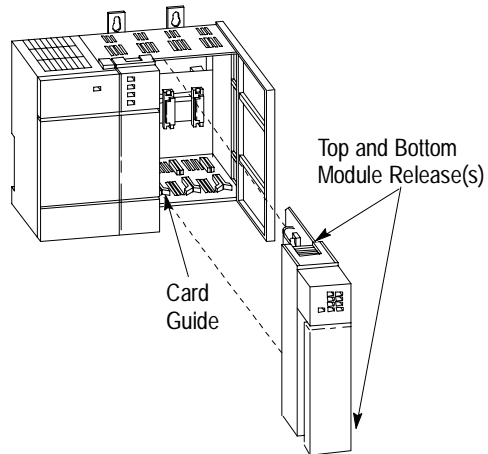

2. Slide your module into the chassis until both top and bottom retaining clips are secure. Apply firm even pressure on your module to attach it to its backplane connector. Never force your module into the slot.

Cover all unused slots with the Card Slot Filler, Allen-Bradley part number 1746-N2.

To remove your module, press the retaining clips at the top and bottom of your module and slide it out.

Wiring Your Module

To wire the terminal block, you need:

- a philips or flat-blade screwdriver
- Belden 8761 (shielded, twisted pair) cable or equivalent
- Each terminal may hold up to two 14 gauge leads.



CAUTION

POSSIBLE EQUIPMENT OPERATION

Before wiring your module, always disconnect power from the SLC 500 system and from any other source to the module.

Failure to observe this precaution can cause unintended equipment operation and damage.

Before wiring the terminal block, take some time to plan your system:

- Ensure that the SLC 500 system is installed in a NEMA-rated enclosure and that the SLC 500 system is properly grounded.
- Ensure that the load resistance for a current output channel is less than 500 ohms.
- Ensure that the load resistance for a voltage output channel is greater than 1 kohms.
- Route the field wiring away from any other wiring and as far as possible from sources of electrical noise, such as motors, transformers, contactors, and ac devices. As a general rule, allow at least 6 in. (about 15.2 cm) of separation for every 120 V of power.
- Routing the field wiring in grounded a conduit can reduce electrical noise further.
- If the field wiring must cross ac or power cables, ensure that they cross at right angles.

To wire your module, follow these steps:

1. Determine the length of cable you need to connect a channel to its field device. Remember to include additional cable to route the shield wire and foil shield to their ground points.
2. At each end of the cable, strip some casing to expose the individual wires.
3. Trim the exposed signal wires to 2 in. lengths. Strip about 3/16 in. (about 5 mm) of insulation away to expose the end of each wire.

- At one end of the cable, twist the shield wire and foil shield together, bend them away from the cable, and apply shrink wrap.

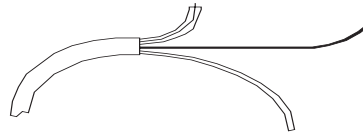

- At the other end of the cable, cut the drain wire and foil shield back to the cable and apply shrink wrap.

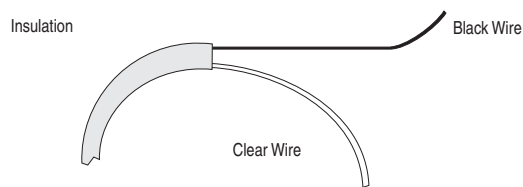

- Connect the wires to the terminal block and field device as shown in the following figures and table. The recommended maximum torque is 5 in-lb (0.565 Nm) for all terminal screws.
- Repeat steps 1 through 6 for each channel on your module.

A system may malfunction due to a change in its operating environment. After installing and wiring your module, check system operation. See the Allen-Bradley system *Installation and Operation Manual* for more information.

Figure 2. Wiring diagrams

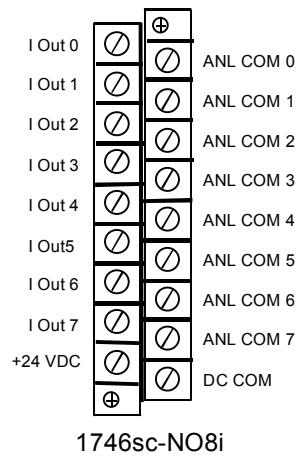
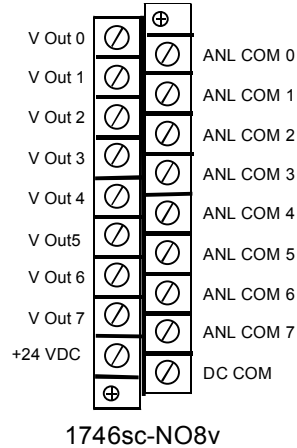

Labeling And Re-Installing The Terminal Block (if it is removed)

The supplied terminal cover has a write-on label. Using this label helps ensure that the terminal block is installed on the correct module.

Once you have wired your module and properly labeled the terminal cover, install the terminal block on your module:

1. Align the terminal block with the receptacle.
2. Insert the terminal block and press firmly at the top and bottom until it is properly seated.
3. Screw in the two retaining screws on the top and bottom of the terminal block.

Things To Consider Before Using Your Module

Read this chapter to familiarize yourself with:

- how the processor communicates with your module
- channel update time
- your module's response to slot disabling

How The Processor Communicates With Your Module

Your processor transfers data to (and receives data from) the processor through an image table residing in the data files of your processor. The processor updates this image table once during each scan of your ladder program. Figure 4 shows the image table for your output module.

Figure 3. Output and input scans

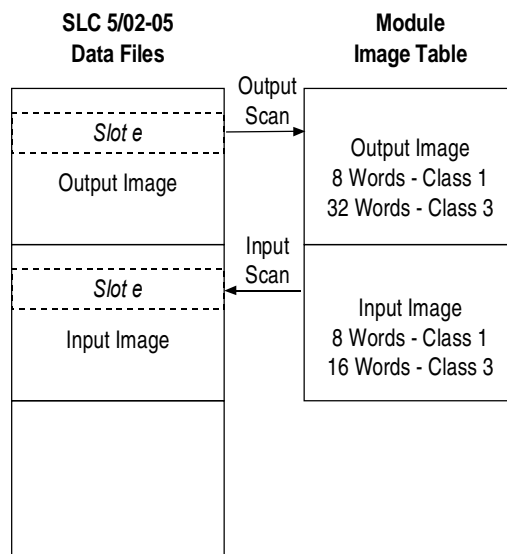

Channel Update Time

For an output module, channel update time is the time required for the module to convert the channel data received from the processor to an analog output signal at the terminals.

Channel update time will vary depending on mode of operation and features implemented:

Table 7. Channel update time (all channels)

Mode	Update Time
Class 1	5 ms
Class 3	10 ms

Your Module's Response To Slot Disabling

By writing to the status file in the modular SLC processor, you can disable any chassis slot. Refer to your SLC programming manual for the slot disable/enable procedure.



CAUTION—POSSIBLE EQUIPMENT OPERATION

Always understand the implications of disabling a module before using the slot disable feature.

Failure to observe this precaution can cause unintended equipment operation.

When you disable an output module's slot, the module holds its outputs in their last state in Class 1 mode. When you re-enable the output module's slot, the data that is in the processor image table is converted to an analog output signal during the next scan. Slot disabling only affects enabled channels. In Class 3 mode the output will go to its fault state, as configured by the user, when the slot is disabled. See the "Set Output Behavior Under Fault Condition" section in the next chapter.

Channel Configuration, Data, and Status

Read this chapter to:

- enter your output module's ID code
- configure each output channel
- set the optional features
- control each output channel's signal
- monitor each output channel
- check each output channel's configuration and status

To use your module, you need:

- programming equipment
- Allen-Bradley RSLogix 500

Entering Your Module's ID Code

Before using your module, you must configure the slot your module is in by entering your module's ID code in RSLogix.

When using RSLogix simply select your module from the list of modules on the system I/O configuration display to automatically enter the ID code.

With earlier versions of RSLogix you must manually enter the ID code. To enter your module's ID code, select "other" from the list of modules on the system I/O configuration display, and enter your module's ID code at the prompt. The module ID code for your module is:

Table 8. Output module ID code

Catalog Number Module ID Code

1746sc-NO8i	3527	Class 1 Mode (8 inputs / 8 outputs)
	12727	Class 3 Mode (16 inputs, 32 outputs)
1746sc-NO8v	3528	Class 1 Mode (8 inputs / 8 outputs)
	12728	Class 3 Mode (16 inputs / 32 outputs)

If you perform the “READ IO CONFIG” option in your RSLogix programming software the module is configured to the respective Class 1 mode if the power is cycled at the PLC if the module has not been previously configured.

Note:

If your module was previously configured for Class 3 operation and you perform READ IO CONFIG and your RSLogix software does not have the NO8 in its I/O pick list, then your module will be set to operate in Class 3 mode. The input and output words will be set to zero. This will likely cause your SLC program to indicate errors upon downloading. To correct this remove the NO8 module from the I/O configuration list-re-add it per the instructions above.

Output Image

Class 1 - The 8-word, output image (defined as the output from the SLC processor to your module) represents the following for the NO8i/v.

- The **output data words** control output signal levels for each channel.

Class 3 - The 32-word, output image (defined as the output from the SLC processor to your module) represents the following for the NO8i/v.:

- The **output data words** control output signal levels for each channel.
- The **configuration bytes** replace configuration DIP switches on your module. In your output module, each word configures one channel.
- The **output data parameters 1 and 2** typically define low and high values for items such as limit alarms and output clamping. Ramping and preset output on fault only use output data parameter 1.

Refer to Figure 4 for addition information.

For more information on the user-defined scale, output clamping, limit alarms, ramping, and preset output on fault see *Setting The Optional Feature Values*, later in this chapter.

Figure 4. Output Image

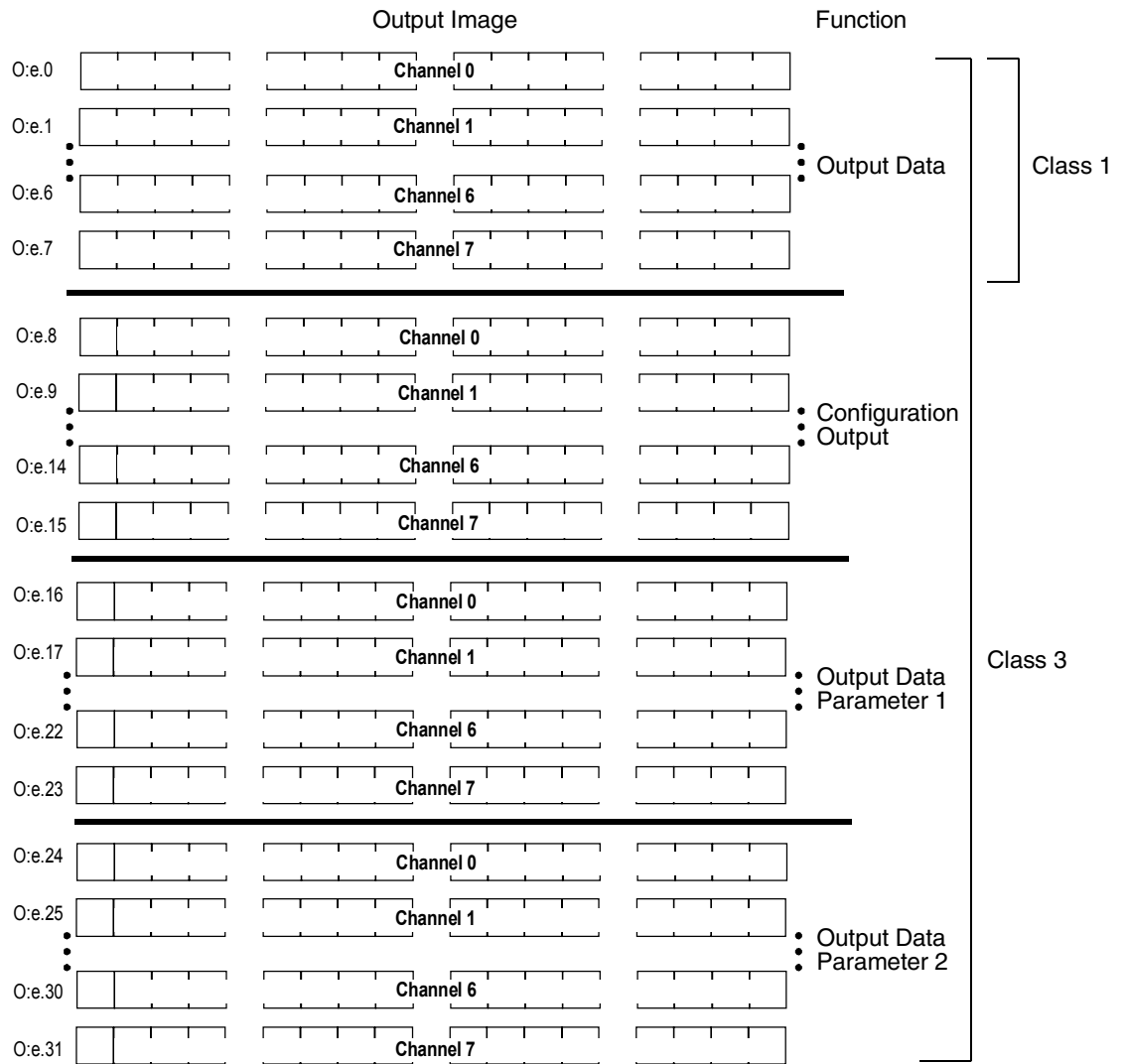

Input Image

Class 1 - The 8-word input image (defined as the input from your module to the SLC processor) holds the data received by your module and provides the status (configuration and operational state) of each channel.

Class 3 - The 16 Word input image holds the data (defined as the input from your module to the SLC processor) holds the data of each channel received by your module and also provides the extended feature set, status and alarming for each channel

Important - Class 3 features for any particular channel will only be active if the channel is enabled. Disabled channels will output 0V (0mA) no matter what features are configured.

Figure 5. Input Image

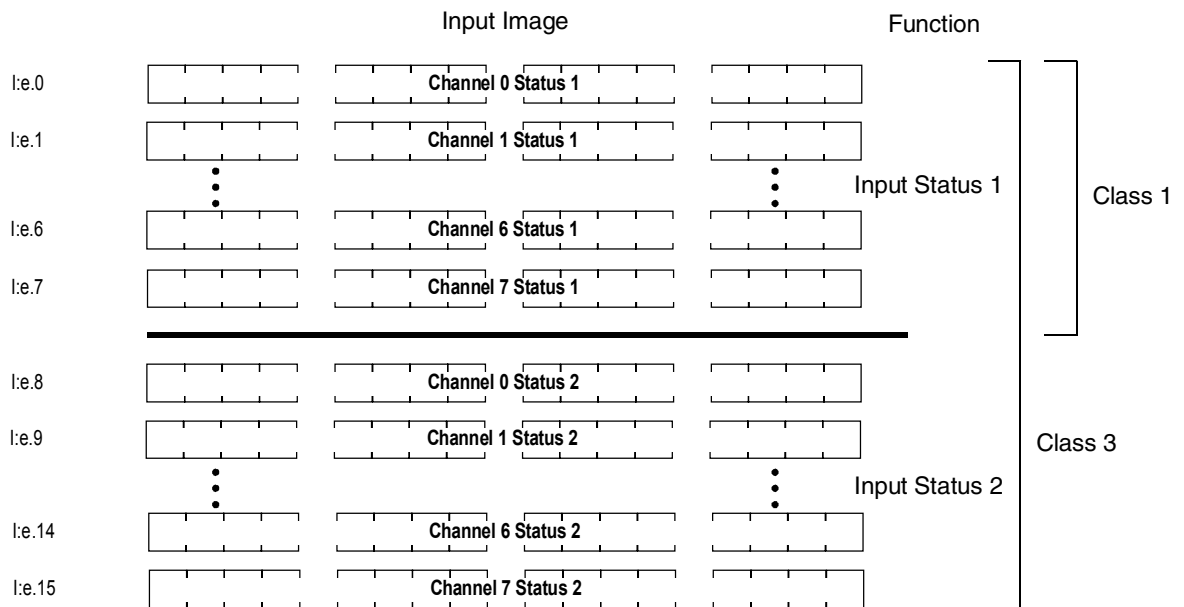

Configuring Each Output Channel

Class 3 Only - After installing your module, you must configure each channel by setting bit values in each configuration word. Input words 8 through 15 of the input image file (addresses O:e.8 and O:e.15) configure channels 0–7 respectively. Refer to Figure 4 for specific addressing.

Table 9. Channel configuration word details, Output Words 8-15 (O:e.8 through O:e.15) for Ch. 0-7 respectively

To select...	Use these bit settings...															
	15	14	13	12	11	10	9	8	7	6	5	4	3	2	1	0
Output channel disable																0
Output channel enable																1
±10 Vdc output range (-NO8v) 0-21 mA output Range (-NO8i)														0	0	
1-5 Vdc output range (-NO8v) 4-20mA output range(-NO8i)														0	1	
0-5 Vdc output range (-NO8v only) 0-20mA output range (-NO8i)														1	0	
0-10 Vdc output range (-NO8v only) N/A output range (-NO8i)														1	1	
invalid													0			
1746-NO4 compatible format										0	0	0				
Engineering units										0	0	1				
Scaled for PID										0	1	0				
Proportional counts										0	1	1				
User-defined scale										1	0	0				
Invalid										1	0	1				
Invalid										1	1	0				
Invalid										1	1	1				
Clear Parameter*									1							
Set Parameter*								1								
No Action					0	0	0									
Set User Scaling Values					0	0	1									
Set Clamping Values					0	1	0									
Set Limit Alarm Values					0	1	1									
Set Ramping / Rate Limiting Values					1	0	0									
Set Preset Fault Values					1	0	1									
Invalid					1	1	0									
Invalid					1	1	1									
Reset Output on Fault				0	0											
Hold Output on Fault				0	1											
Preset Output on Fault				1	0											
Invalid				1	1											
Latch Alarms		1														
Reset Latched Alarms	1															

*A configuration error will occur if these bits are set to 1 at the same time.

Output Channel Enable (configuration bit 0)

Use this bit to enable or disable a channel.

Output Range (configuration bits 1–2)

Use this bit field to configure the channel voltage or current output range for the type of output device you have connected to the module.

Data Format (configuration bits 4–6)

Use this bit field to select one of the following formats:

- 1746-NO4 compatible format (the format used by the 1746-NO4)
- engineering units (mV or nA)
- scaled for PID (works with the SLC PID instruction)
- proportional counts (two's complement binary)
- user-defined scale

These data formats and ranges are defined in the following table:

Table 10. Data format definitions

Data Format	Selected Output Range	Data Value (counts)		Corresponding Signal	
		Min.	Max.	Min.	Max.
1746-NO4- Compatible (See Note 1)	±10 V	-32768	+32767	-10 V	+10 V
	0–10 V	0	+32767	0 V	+10 V
	0–5 V	0	+16384	0 V	+5 V
	1–5 V	+3277	+16384	+1 V	+5 V
	0–20 mA	0	+31208	0 mA	+20 mA
	0–21 mA	0	+32767	0 mA	+21 mA
	4–20 mA	+6242	+31208	+4 mA	+20 mA
Engineering Units	±10 V	-10250	+10250	-10.25 V	+10.25 V
	0–10 V	-500	+10250	-0.50 V	+10.25 V
	0–5 V	-500	+5500	-0.50 V	+5.50 V
	1–5 V	+500	+5500	+0.50 V	+5.50 V
	0–20 mA	0	+20500	0.0 mA	+20.5 mA
	0–21 mA	0	+21500	0.0 mA	+21.5 mA
	4–20 mA	+3500	+20500	+3.5 mA	+20.5 mA
Scaled for PID	±10 V	0	+16383	-10 V	+10 V
	0–10 V	0	+16383	0 V	+10 V
	0–5 V	0	+16383	0 V	+5 V
	1–5 V	0	+16383	+1 V	+5 V
	0–20 mA	0	+16383	0 mA	+20 mA
	0–21 mA	0	+16383	0 mA	+21 mA
	4–20 mA	0	+16383	+4 mA	+20 mA
Proportional Counts	±10 V	-32768	+32767	-10.25 V	+10.25 V
	0–10 V	-32768	+32767	-0.50 V	+10.25 V
	0–5 V	-32768	+32767	-0.50 V	+5.50 V
	1–5 V	-32768	+32767	+0.50 V	+5.50 V
	0–20 mA	-32768	+32767	0.0 mA	+20.5 mA
	0–21 mA	-32768	+32767	0.0 mA	+21.5 mA
	4–20 mA	-32768	+32767	+3.5 mA	+20.5 mA
User-Defined Scale (See note 2)	±10 V			-10.25 V	+10.25 V
	0–10 V			-0.50 V	+10.25 V
	0–5 V			-0.50 V	+5.50 V
	1–5 V			+0.50 V	+5.50 V
	0–20 mA			0.0 mA	+20.5 mA
	0–21 mA			0.0 mA	+21.5 mA
	4–20 mA			+3.5 mA	+20.5 mA

1 Provides direct compatibility with the 1746-NO4 module.

2 For the user-defined scale, the data in output data parameter word 1 and 2 determine the count limits. See the next subsection, *User-Defined Scale*, for information on the User-Defined Scale data format.

Set Optional Feature
Values
(configuration bits 7-11)
(Class 3 Only)

These bits are used to load the values from data parameter 1 and 2 into the corresponding feature. Setting these values also enables most features.

- User Scaling Values
- Clamping Values
- Limit Alarm Values
- Ramping / Rate Limiting Value
- Preset Fault Value

Note: Once the data parameters have proper values and bits 9-11 are set, then set bit 8 (set optional feature) to set the feature or set bit 7 (clear optional feature) to clear the feature.

Setting The Output Data
Words (Class 3 Only)

Output Data Parameter Words 1 and 2 of the output image file (addresses O:e.16 through O:e.31 let you define either:

Output Data Parameter Word 1 (O:e.16-O:e.23)

- Set User Scaling Values: User Scale Low Value
- Set Clamping Values: User Clamping Low Value
- Set Limit Alarm Values: Limit Alarm Low Value
- Set Ramping/ Rate Limiting Values: Ramping Rate (0-3276.7 millivolts(milliamps)/second)
- Set Preset fault value

and

Output Data Parameter Word 2 (O:e.24-O:e.31)

- Set User Scaling Values: User Scale High Value
- Set Clamping Values: User Clamping High Value

- Set Limit Alarm Values: Limit Alarm High Value

Optional Features - Class 3 Only

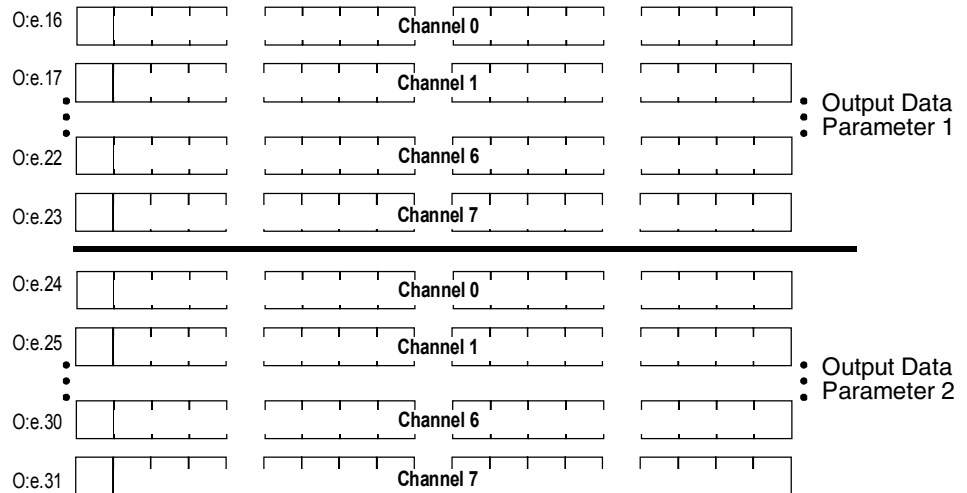

Important – The values in output word pairs 16 through 31 apply to each individual channel. If you want to use any of these features you must set each channel’s output word pair.

Changing the output data format or range (Bits 1-6 of the channel configuration word) will clear or disable user scaling, clamping, limit alarms, ramping/rate limiting and preset fault values.

Similarly, if format or range is changed you must reconfigure the values for each of these features.

User-Defined Scale

For special applications, the 1746sc-NO8i and 1746sc-NO8v output modules let you define a custom data format. This “user-defined scale” is very similar to the “proportional counts” data format—except that instead of converting the output data to an output signal using a previously defined scale (-32,768 to 32,767), your module converts the output data using a scale defined by the values in output words 16 (low limit of scale) and 24 (high limit of scale) for channel 0.

The high limit value must be greater than the low limit value for proper operation. Also, the difference between the low and high values should be greater than 1024 counts. If the difference between the low and high values is less than 1024 counts, unexpected results can occur (especially at the extreme ends of the range).

You select the data format for each channel using that channel's configuration bits, described in the previous subsection, *Configuring Each Output Channel*.

The user low value (Output Data Parameter 1) is the value that will set the output to the selected output range's minimum value. Similarly, the user high value (Output Data Parameter 2) is the output data value that will set the output range's maximum value.

Example – Suppose you have a valve connected to channel 0 with a 4–20 mA range, and you want your scale to go from 100 to 9999 counts. For a 4–20 mA output with user-defined scaling, your module sets the signal limits to 3.5 mA and 20.5 mA (see Table 10). Enter 100 and 9999 into output words 16 and 24, respectively and setting the output configuration word for the channel to set the user defined scale values and be in user defined scale, the relationship between data value (counts) and output signal would be as follows:

O:e.16 value = 100 decimal (Ch. 0 data parameter 1)
 O:e.24 value = 9999 decimal (Ch. 0 data parameter 2)

Now set the proper bits in the channel 0 configuration word.

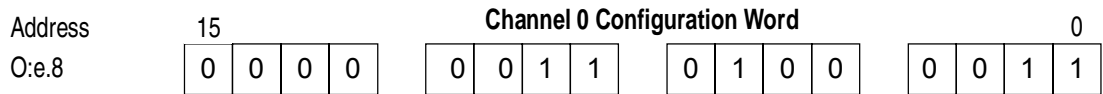

Monitor Bit 0 of channel 0 input status word 2 (I:e.8). When this bit is 1 (user scaling values set) then set the channel 0 configuration to be User Scaling.

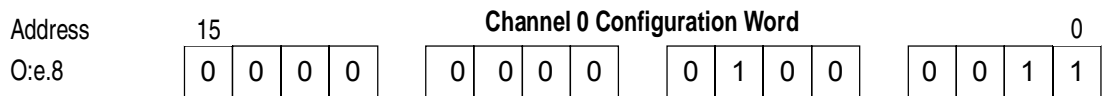
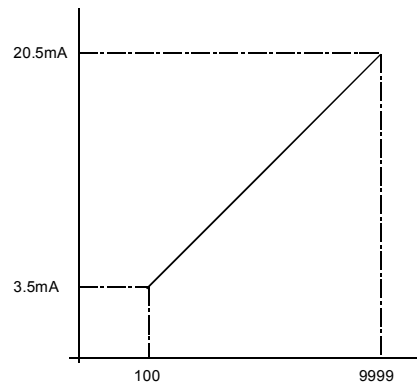

Figure 5. Example relationship between output signal and channel data



Output Clamping

For added safety, the 1746sc-NO8i and 1746sc-NO8v output modules let you define limits for the values in the output data words individually for all eight channels. These data limits, in turn, limit the output signals that your module provides. When an output data word exceeds the data limit, the output value is truncated to the limit.

You can use output data limiting to prevent PID loops from exceeding safety limits, to prevent operators from inadvertently setting incorrect values, etc.

The low clamping limit (output data parameter 1) is the value which the output signal will not go below. The high clamping limit (output data parameter 2) is the value which the output signal will not go above.

For some ranges and formats the clamp alarms will occur a few counts from the set clamping values. This means you may need to command an output value lower or higher than the output clamping limits in order to get output at low/high clamp alarms.

The low clamp limit value must be lower than the high clamp limit value.

Example – Suppose you have a valve connected to channel 0 with a ± 10 V operating range, and you want to use the Engineering Units data format. For this application, you would use the following bit settings for the channel configuration bytes:

Address	15	Channel 0 Configuration Word												0			
O:e.8		0	0	0	0	0	0	0	0	0	0	0	1	0	0	0	1

Suppose, also, that you would like to set the output limits to -2 V and +8 V. You would enter the following for channel 0 data parameters 1 and 2:

O:e.16 Value = -2000 decimal (-2V)
 O:e.24 Value = 8000 decimal (+8V)

Now, by setting bit 8 and 10 in the Channel 0 configuration word, the output will be clamped to -2 to +8 volts.

Address	15	Channel 0 Configuration Word												0			
O:e.8		0	0	0	0	0	1	0	1	0	0	0	1	0	0	0	1

Monitor bit 1 of the channel input status word 2 (I:e.8). When the bit is 1 (clamping values set) then set the channel 0 configuration back to its original value.

Address	15	Channel 0 Configuration Word												0			
O:e.8		0	0	0	0	0	0	0	0	0	0	0	1	0	0	0	1

Your Channel 0 data output will now look like this.

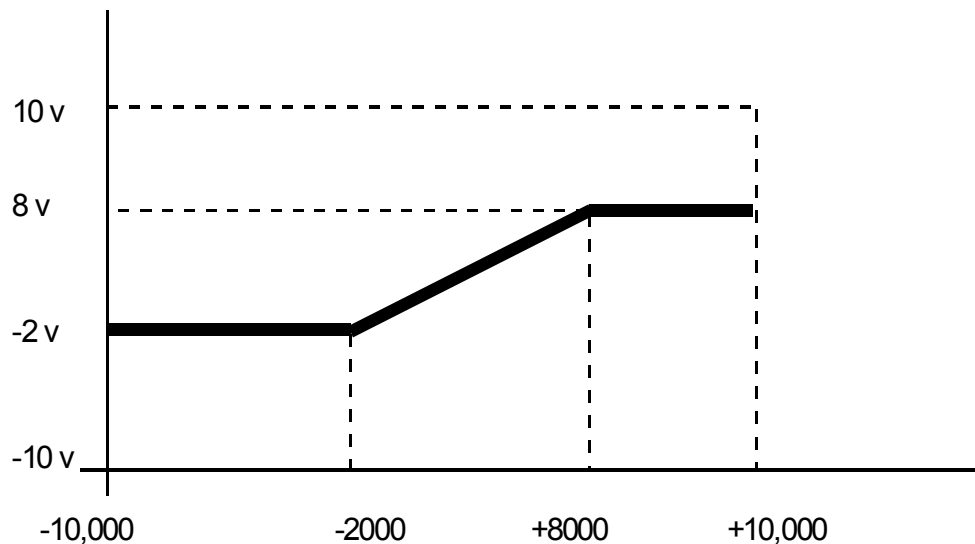

Note that whenever the requested output data values meet or attempt to exceed the output data limits, your module sets bits 9 or 10 in the channel input status 2 word (I.e.8 for Ch. 0) to indicate a clamp alarm.

Set Limit Alarm Values

This feature allows alarming if the value output from the card is the same or higher than the limit alarm high value or the same or lower than the limit alarm low value. It can be set on a channel by channel basis. The limit alarm low and high values are configured by placing the desired value into the Output Data Parameter Word 1 and 2, respectively, for the desired channel then setting the Output Configuration Word for the channel to Set the Limit Alarm Values

The limit alarm values are based on the same data format and output range configured for the channel.

Note: For some ranges and formats the limit alarms will occur a few counts off from the set limit alarm values. You may need to adjust the limit alarm values until the desired alarm limit occurs.

For Example: Suppose you have a valve connected to channel 6 with a 0-20ma operating range and you want to use the NO4 compatible format. You would use the following settings for the channel 6 configuration word.

Address	15	Channel 6 Configuration Word												0			
O:e.14		0	0	0	0	0	0	0	0	0	0	0	0	0	1	0	1

Suppose, also, that you would like to provide an alarm if the output data word was commanded to less than 100 counts and greater than 30,000 counts. You would enter the following for channel 6 data parameter 1 and 2.

O:e.22 Value = 100 decimal
 O:e.30 Value = 30000 decimal

Now set the proper bits in the channel 6 configuration word.

Address	15	Channel 6 Configuration Word												0		
O:e.14	0	0	0	0	0	1	1	1	0	0	0	0	0	1	0	1

Monitor Bit 2 of the channel 6 input word 2 (I:e. 14) when the bit is a 1 (Limit Alarms Valves Set) then set the channel 6 configuration back to it's original value.

Address	15	Channel 6 Configuration Word												0		
O:e.14	0	0	0	0	0	0	0	0	0	0	0	0	0	1	0	1

Set Ramping / Rate Limiting Values

This feature allows the output to change at a user configured rate. It limits the rate at which the output will change. This can be set on a channel by channel basis. The Ramping/ Rate Limiting value for a channel is configured by placing the desired value into the Output Data Parameter Word 1 for the desired channel then setting the Output Configuration Word for the channel to Set the Ramping/Rate Limiting Value

The ramping/rate limiting value that is placed in the output data parameter 1 can be calculated by using the following equation:

$$1746\text{-NO}8v, \text{ Value} = (\text{Change in Volts} / \#\text{seconds for the change}) * 10$$

$$1746\text{-NO}8i, \text{ Value} = (\text{Change in Current} / \#\text{seconds for the change}) * 10$$

The Ramping/Rate Limiting value is defined as 100mv/second for the voltage card and 0.1ma/second for the current card for all data formats and data ranges. For example a value of 40 equates to 4 volts/second. This means if the channel was commanded to go from 2 to 8 volts it would take $(8-2)/4 = 1.5$ seconds to get there.

Example – Suppose you have a valve connected to channel 4 with a 4 – 20mA operating range and you want to use PID format. You would use the following bit settings for the channel 4 configuration word:

Address	15	Channel 4 Configuration Word												0		
O:e.12	0	0	0	0	0	0	0	0	0	0	1	0	0	0	1	1

Suppose, also, that you would like the output to change no more than 1.5 mA per second. Since the ramping value is expressed as 0.1 mA per second your value would be $1.5 \div 0.1 = 15$. You would enter the following

for channel 4 data parameter 1. Note, data parameter 2 is not used for ramping:

O:e.20 Value=15 decimal
(Ch 4 Data Parameter 1) (1.5mA per second)

Now set the proper bits in the channel 4 configuration word:

Address	15	Channel 4 Configuration Word												0			
O:e.12		0	0	0	0	1	0	0	1	0	0	1	0	0	0	1	1

Monitor bit 3 of channel 4 input status word 2 (I:e.12). When this bit is a 1 (Ramping/ Rate Limiting value set) then set the channel 4 configuration back to its original value:

Address	15	Channel 4 Configuration Word												0			
O:e.12		0	0	0	0	0	0	0	0	0	0	1	0	0	0	1	1

Ramping is now active.

Set Preset Fault Value

This feature allows the user to define a preset output value for a fault condition. The value for a channel is configured by placing the desired value into the Output Data Parameter Word 1 for the desired channel then setting the Output Configuration Word for the channel to Set the Preset Value. The module will revert to this value when a fault condition occurs, if the preset output on fault is set.

Example – Suppose you have a valve connected to channel 7 with a 4 – 20mA operating range and you want to use Engineering Units format. You would use the following bit settings for the channel 7 configuration word:

Address	15	Channel 7 Configuration Word												0			
O:e.15		0	0	0	0	0	0	0	0	0	0	0	1	0	0	1	1

Suppose, also, that you would like the output to go to 12 mA if a fault condition occurred such as the SLC went into program mode (See Set Output Behavior under Fault Condition section for information about fault conditions.) You would enter the following for channel 7 data parameter 1. Note, data parameter 2 is not used for the Preset Fault Value:

O:e.15 12000 (decimal) Channel 7 data parameter 1

Now set the proper bits in the channel 7 configuration word:

Address	15	Channel 7 Configuration Word												0			
O:e.15		0	0	0	0	1	0	1	1	0	0	0	1	0	0	1	1

Monitor bit 4 of channel 7 input status word 2 (I:e.15). When this bit is a 1 (Preset Fault Value set) then set the channel 7 configuration back to its original value with the addition of setting the channel 7 configuration word to preset output on fault (bit 13):

Address	15	Channel 7 Configuration Word												0			
O:e.15		0	0	1	0	0	0	0	0	0	0	0	1	0	0	1	1

If a fault is detected then the output for channel 7 will go to 12 mA.

Set Output Behavior under Fault Condition (configuration bits 12-13)

This setting allows the user to define the output state when a fault condition occurs. The output may be set to reset, hold current value or go to a preset value. In Class 1 operation of the output will be set to the reset value when a fault condition occurs. One exception for Class 1 is if the module's chassis slot is disabled. Then the output will hold its current value.

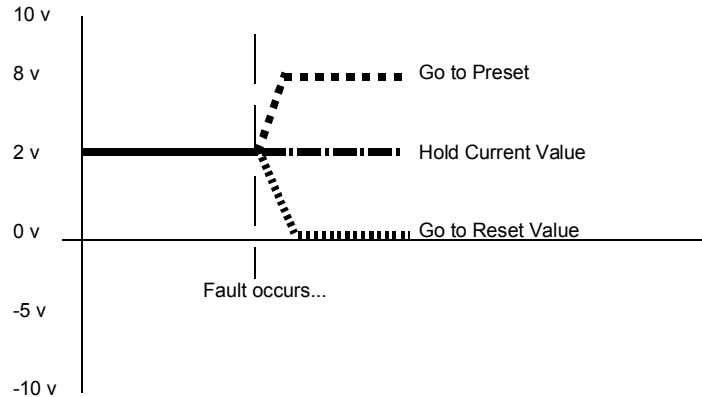

Note: If a channel is configured to “preset output on fault” (bit 12 = 0 and bit 13 = 1) and no preset fault value was previously set, then the output will go to the reset value (0V or 0mA) when a fault condition occurs.

Note: It is recommended that “reset output on fault” is set when a channel is disabled.

A fault is defined as:

- 1) CPU Fault
- 2) Rack power goes away while the external 24V power remains

Note: When the rack power is restored the channel outputs will go to the reset power state during power on self test. After this the channels will output their commanded values if enabled with a valid configuration.

- 3) CPU goes out of run mode
- 4) The modules chassis slot is disabled

Note: In Class 1 operation the output will hold the current value when the module’s chassis slot is disabled.

Alarms Latch (configuration bit 14)

This setting allows certain alarms to remain latched. This can be useful if alarm conditions need to be acknowledged by an operator. Over/Under Limit, Over/Under Range Output at low/high Clamp Alarm, Open Current Loop and 24v Power Failure alarms are latched when this feature is enabled. Channel Configuration Error, Fatal Channel Error and Module/SLC Resetting alarms are not latched and unaffected by this feature setting.

Note: The set and clear parameter feature bits (Bits 7 and 8 of the channel configuration word) must be zero for the latched alarms to operate.

When the Latch Alarms configuration bit is cleared for a channel then the alarm bit allows the alarm condition. If the alarm condition occurs then the alarm bit is set. If the alarm condition goes away then the alarms bit is cleared.

**Reset Latched Alarms
(configuration bits 15)**

When the Latched Alarms configuration bit is set for a channel and if the alarm condition occurs and goes away, the bit stays set. Only if the alarm condition is gone and the Reset Latched Alarms configuration bit is set will the alarm bit be cleared. If the alarm condition exists and the Reset Latched Alarms configuration bit is set, the alarm bit stays set.

**Channel's Configuration
And Status (Class 1 and
3)**

Words 0 through 7 of the input image file (addresses I:e.0 through I:e.7) reflect the configuration and status of each channel. Use the data provided in these status words to determine various channel conditions.

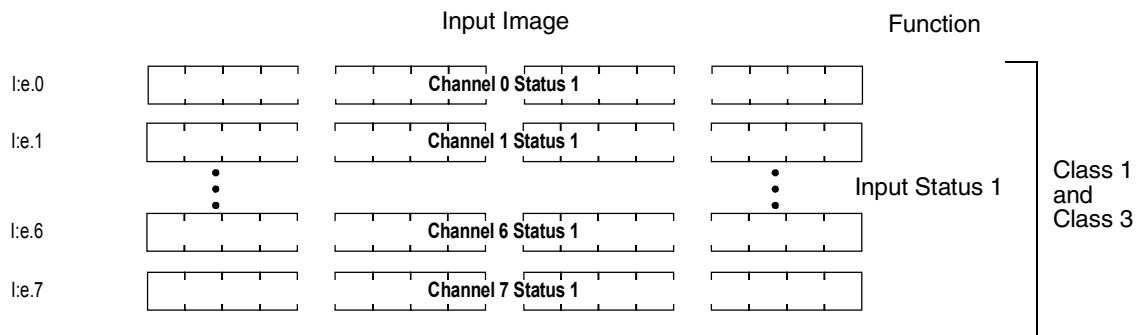

Table 12. Channel Status 1 word details, Input Words 0-7 (I:e.0 through I:e.7) for Ch. 0-7 respectively

To select...	Use these bit settings...															
	15	14	13	12	11	10	9	8	7	6	5	4	3	2	1	0
Output channel disabled																0
Output channel enabled																1
±10 Vdc output range (-NO8v) 0-21 mA output Range (-NO8i)														0	0	
1-5 Vdc output range (-NO8v) 4-20mA output range(-NO8i)														0	1	
0-5 Vdc output range (-NO8v only) 0-20mA output range (-NO8i)														1	0	
0-10 Vdc output range (-NO8v only) N/A output range (-NO8i)														1	1	
Invalid													0			
1746-NO4 compatible format										0	0	0				
Engineering units										0	0	1				
Scaled for PID										0	1	0				
Proportional counts										0	1	1				
User-defined scale										1	0	0				
Invalid										1	0	1				
Invalid										1	1	0				
Invalid										1	1	1				
Invalid						0	0	0	0	0						
24 V Power Failure				1												
Current Loop Open			1													
Module / SLC Resetting		1														
Fatal Channel Error	1															

Output Enable Echo (Status Bit 0)

This bit shows the current channel status. The channel is enabled when this bit echo is 1.

Output Range Echo (Status Bits 1-2)

These bits echo the current output range for the active channel.

Unused (Status Bit 3)**Scale Echo (Status Bits 4-6)**

This bit shows the current channel format setting.

Unused (Status Bits 7-11)

24 V Power Failure Echo (Status Bit 12)

This bit is set to one if the external 24VDC power supply being used (Selected via Jumper J4) has failed. The external 24VDC is used to power the analog output circuitry. This bit will clear when the external 24VDC supply is present and, if the Latch Alarms feature is enabled, the Reset Latched Alarms bit has been set or toggled.

Open Current Loop (Status Bit 13)

This bit is set to one if there is no load (open loop) on the output channel. Open loop detect will only be indicated if the current being commanded is greater than 0.1ma. Invalid open loop detection may occur if the channel load resistance is greater than the specified maximum resistance of 500 ohms or less than 0.1ma is commanded. This bit will clear when the channel is no longer in an open loop condition (or commanding less than 0.1ma) and, if the Latch Alarms feature is enabled, the Reset Latched Alarms bit has been set or toggled.

Module / SLC Resetting (Status Bit 14)

This bit is set to one whenever the module or SLC is resetting. The bit will clear when both the module and the SLC are not resetting. This bit is not latched by the Latch Alarm feature. Do not send configuration data to the module when this bit is set

Fatal Channel Error (Status Bit 15)

This bit is set to one whenever your module detects a “non-recoverable” channel error, such as a software power-up failure due to corrupt hardware or malfunctioning software. You may be able to recover from this type of error by resetting the SLC 500 processor or cycling power to your module. This bit is not latched by the Latch Alarm feature

User Scaling Values Set (Status Bit 0)

This bit indicates that user scaling values have been set for this channel. If the channel format is user scaling and the channel is enabled, user scaling is active.

Clamping Values Set (Status Bit 1)

This bit indicates that clamping values have been set for the channel. If the channel is enabled then clamping is active.

Limit Alarm Values Set (Status Bit 2)

This bit indicates that limit alarms have been set for the channel. If the channel is enabled then limit alarms is active.

Ramping/Rate Limiting Value Set (Status Bit 3)

This bit indicates that ramping / rate limiting has been set. If the channel is enabled then ramping/rate limiting is active.

Preset Fault Value Set (Status Bit 4)

This bit indicates that a user defined fault value is set for this channel. (See “Set Output behavior Under Fault Condition” in the previous section for fault conditions.)

Reset Output On Fault (Status Bit 5)

This bit indicates that the output for this channel will be reset if a channel fault occurs.

(See “Set Output behavior Under Fault Condition” in the previous section for fault conditions.)

Hold Output On Fault (Status Bit 6)

This bit indicates that the channel output value will be held to the current value when a channel fault occurs.

(See “Set Output behavior Under Fault Condition” in the previous section for fault conditions.)

Preset Output On Fault (Status Bit 7)

This bit indicates that the channel output will go to the user defined preset when a channel fault occurs.

(See “Set Output behavior Under Fault Condition” in the previous section for fault conditions.)

Alarms Will Be Latched (Status Bit 8)

This bit indicates that the channel alarms will latch if an error occurs.

When this bit is set and an alarm condition occurs. The Alarm Status bit will stay set until you reset the bit using the Reset Latched Alarms bit.

Output At Low Clamp Alarm (Status Bit 9)

This bit indicates that the channel output data value is being commanded to go below the user defined low clamp value.

Output At High Clamp Alarm (Status Bit 10)

This bit indicates that the channel output data value is being commanded to go above the user defined high clamp value.

Low Limit Alarm (Status Bit 11)

This bit indicates that the channel output has gone below the user defined limit low limit alarm value.

High Limit Alarms (Status Bit 12)

This bit indicates that the channel output has gone above a user defined high limit alarm value.

Under Range Alarm (Status Bit 13)

This bit indicates that the channel data value is being commanded to go below the selected output range.

Over Range Alarm (Status Bit 14)

This bit indicates that the channel data value is being commanded to go above the selected output range.

Channel Configuration Error (Status Bit 15)

This bit indicates that a channel configuration error has occurred. Review the configuration word for setting descriptions.

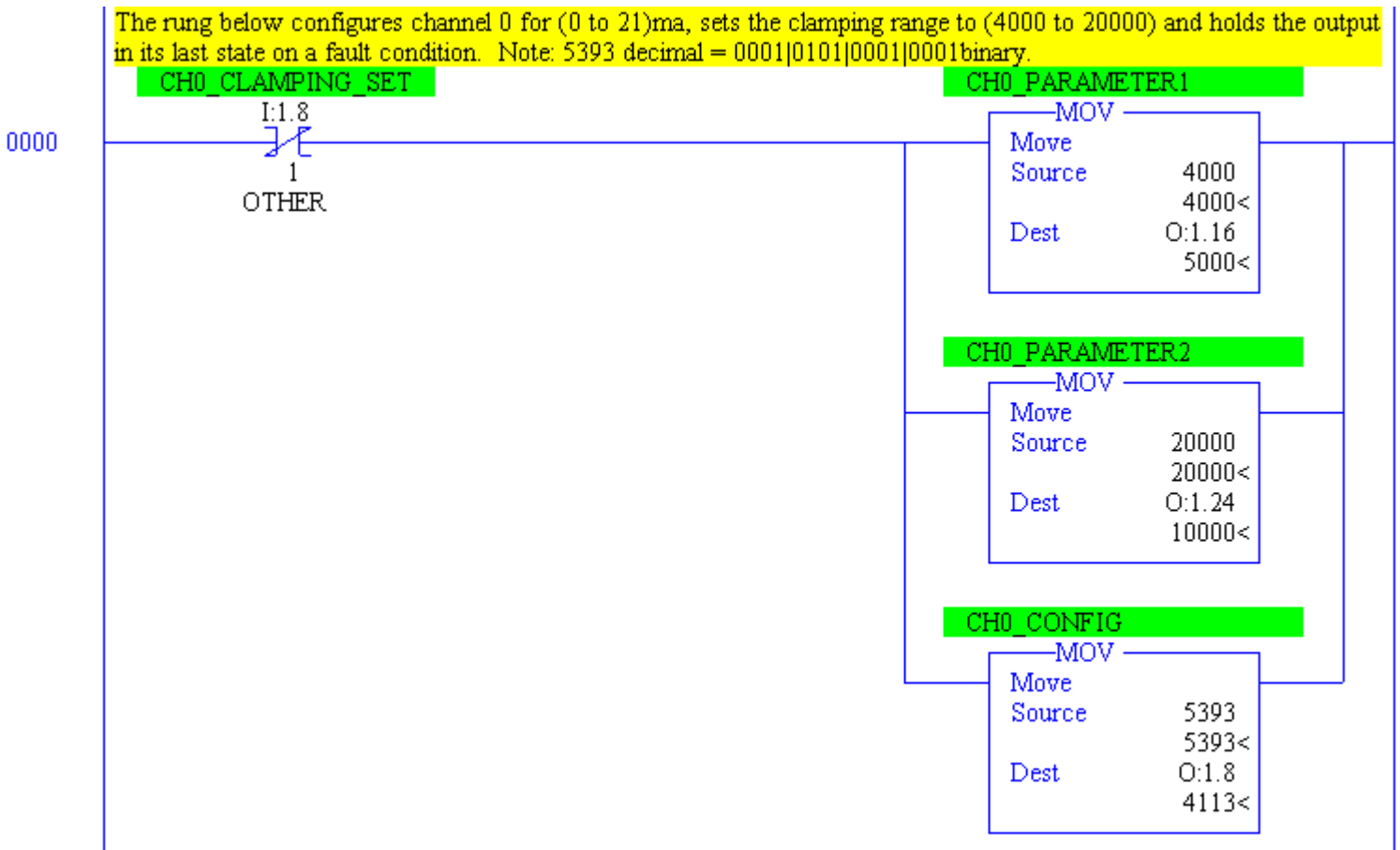
Ladder Logic Sample

The rung below configures channel 0 for (0 to 21)ma, sets the alarm limit range from (5000 to 10000) and holds the output in its last state on a fault condition. Note: 5905 decimal = 0001|0111|0001|0001 binary.

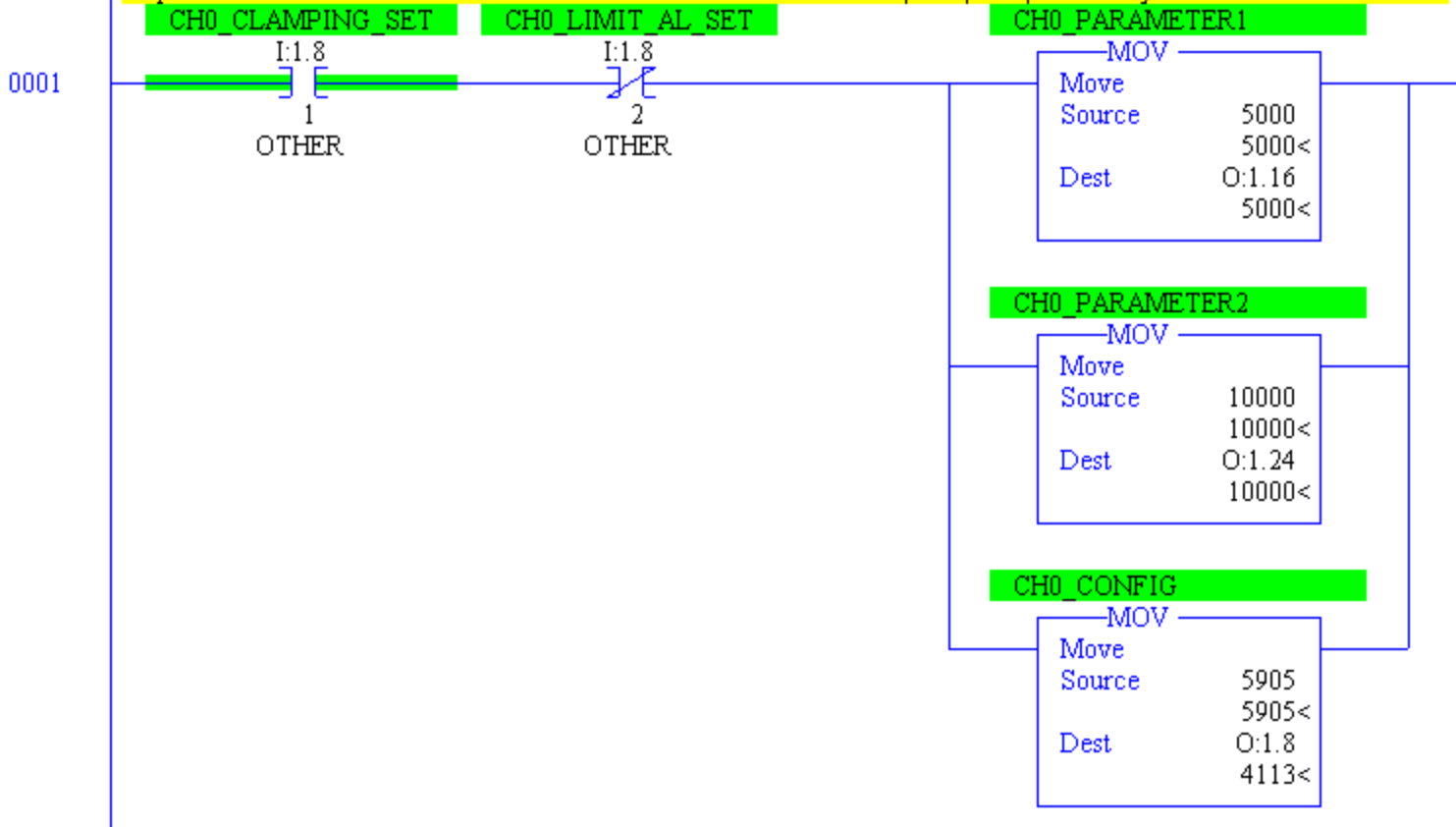

The rung below configures channel 0 for (0 to 21)ma, sets the optional feature to the "no action" state and holds the output in its last state on a fault condition. Note: 4113 decimal = 0001|0000|0001|0001 binary.

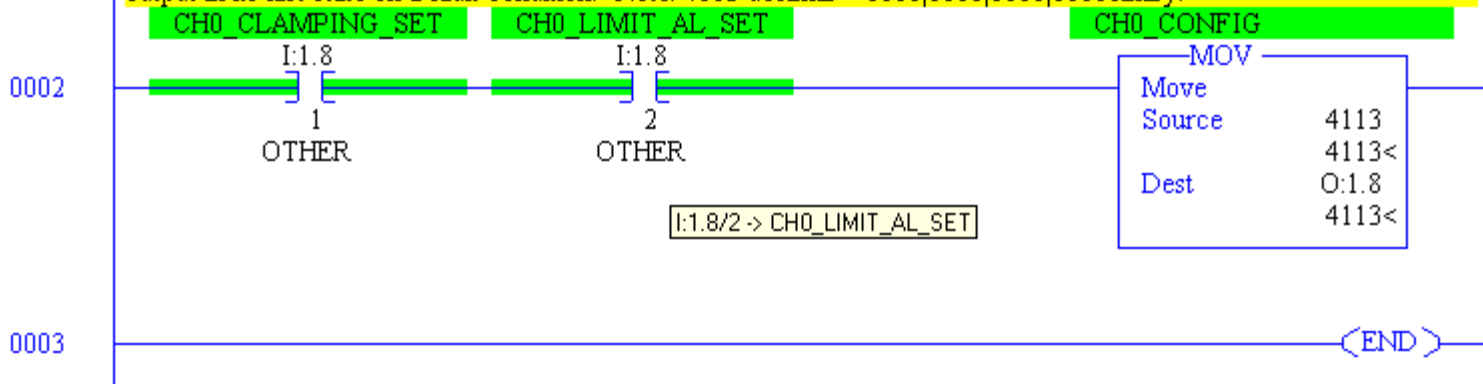

Testing Your Module

Read this chapter to prevent potential problems. This chapter covers:

- inspecting your module
- disconnecting prime movers
- powering up
- interpreting the LED indicators
- interpreting I/O error codes
- troubleshooting

Before testing your module, test your SLC 500 system using the procedures described in your Allen-Bradley system *Installation & Operation Manual*.

Important — If your module appears to be functioning, but the terminals aren't providing an output signal, the 24 Vdc power source (backplane or external) may not be providing enough current (250 mA-NO8i, 160 mA-NO8v).

Inspecting Your Module

You can prevent many potential problems by simply inspecting your analog module:

1. Ensure that the external 24 Vdc jumper, J4, is set properly:
 - With the jumper in the **RACK** position, the module draws all its power from the backplane of the SLC system.
 - With the jumper in the **EXT** position, the module draws its 24 Vdc power from an external power source; however, the module still draws its 5 Vdc power from the backplane.
2. Ensure that all wire connections are correct and secure and that no wires are missing or broken. Refer to Chapter 2, *Installing And Wiring Your Module*, for more information.
3. Ensure that the shield for the cable used to wire your module is properly grounded.
4. Ensure that the removable terminal block on your module is secure.

Disconnecting Prime Movers

Before testing your module, ensure that machine motion will not occur:

- Disconnect motor wires at the motor starter or the motor itself. This lets you test the operation of the starter coil, verifying that the output circuit is wired correctly and functioning.
- Disconnect solenoids by disengaging the solenoid valves, leaving the coils connected.

If you cannot disconnect a device in the preferred way, open the output circuit as close as possible to the motion-causing device.

Example – If you have a relay coil that in turn energizes a motor starter and you cannot disconnect the motor wires, open the circuit at a point between the motor starter and the relay contact.



WARNING

POSSIBLE UNEXPECTED MACHINE MOTION

During all testing, always disconnect all devices that, when energized, might cause machine motion.

Failure to observe this precaution can cause equipment damage or personal injury.

Powering Up

When you apply power to the system, your module's LEDs should illuminate, indicating that your module is receiving power and has completed its onboard self-test. If the LEDs do not illuminate after several seconds, your module is not functional. Discontinue testing until you can get the LEDs to illuminate.

The most probable reasons for the LED not illuminating are:

- The SLC 500 system is not receiving power from its power supply.
- The rest of the SLC 500 system is not receiving power.
- The rack slot where your module is located is defective.
- Your module is defective.

Interpreting The LED Indicators

Your output module has 9 LEDs: 8 channel status LEDs (numbered 0–7 for channels 0–7, respectively) and 1 module status LED.

Figure 6. LED block

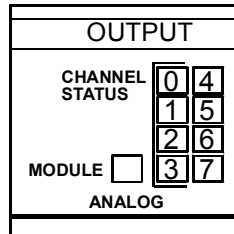

Use the following table to interpret the LEDs:

Table 12. LED definition

If the module status LED is...	And the channel status LED is...	Then...
On	On	The channel is enabled.
	1 Blink	Open circuit.
	2	Unused configuration word bits are set.
	3	Illegal range.
	4	Illegal format.
	5	Illegal parameter ID.
	6	User range error (e.g. User_min > User_max).
	7	Clamp range error.
	8	Illegal fault action.
	9	Illegal ramp value.
	10	Illegal limit range
	11	Illegal preset
	12	Illegal Optional Features
Off	Off	Either your module is powering up or the channel is disabled.
	1 Blink	24V power fail.
	2	Configuration error.
	3	EEPROM fault
	4	SPIOGA2 RAM fault
	5	SPIOGA2 Input Access ERROR
	6	SPIOGA2 Output Access ERROR
	7	ROM CRC failed.

Note: If the module is configured to use an external +24V supply, the supply must be turned on for the module to operate. If the external +24V supply is turned off, the module's outputs will be turned off, and the module's processor will be reset until power is restored.

Interpreting I/O Error Codes

I/O error codes appear in word S:6 of the SLC processor status file. The first two digits of the error code identify the slot (in hexadecimal) with the error. The last two digits identify the I/O error code (in hexadecimal).

The error codes that apply to your module include (in hexadecimal):

- 50–5E
- 71 (watchdog error)
- 90–94

For a description of the error codes, refer to the *Allen-Bradley Advanced Programming Software (APS) Reference Manual*, Allen-Bradley publication 1746-6.11.

Troubleshooting

Figure 7. Problem resolution flowchart

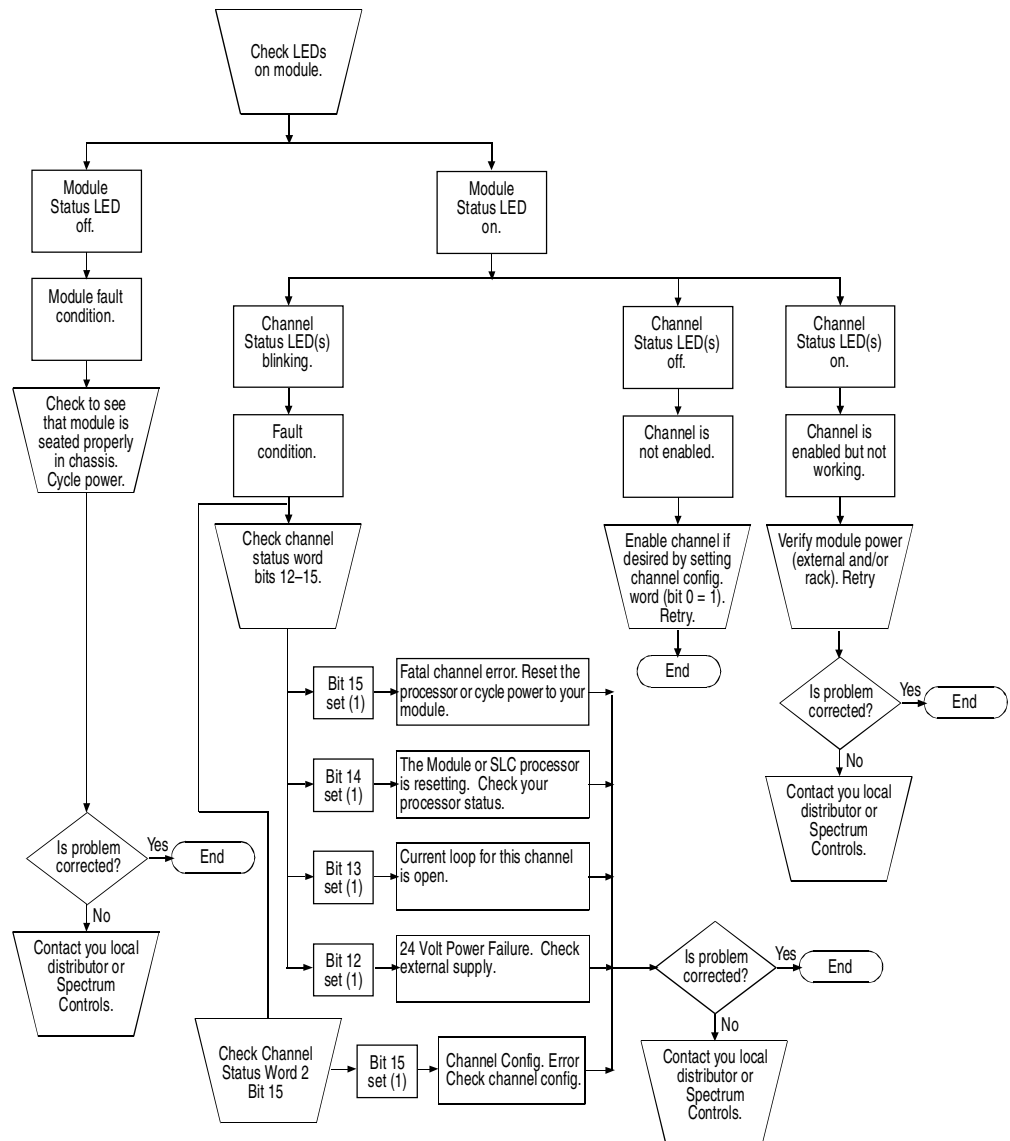

Maintaining Your Module And Ensuring Safety

Read this chapter to familiarize yourself with:

- preventive maintenance
- safety considerations

The National Fire Protection Association (NFPA) recommends maintenance procedures for electrical equipment. Refer to article 70B of the NFPA for general safety-related work practices.

Preventive Maintenance

The printed circuit boards of your module must be protected from dirt, oil, moisture, and other airborne contaminants. To protect these boards, install the SLC 500 system in an enclosure suitable for its operating environment. Keep the interior of the enclosure clean, and whenever possible, keep the enclosure door closed.

Also, regularly inspect the terminal connections for tightness. Loose connections may cause a malfunctioning of the SLC system or damage to the components.



WARNING

POSSIBLE LOOSE CONNECTIONS

Before inspecting connections, always ensure that incoming power is OFF.

Failure to observe this precaution can cause personal injury and equipment damage.

Safety Considerations

Safety is always the most important consideration. Actively think about the safety of yourself and others, as well as the condition of your equipment. The following are some things to consider:

Indicator Lights – When the module status LED on your module is illuminated, your module is receiving power.

Activating Devices When Troubleshooting – Never reach into a machine to activate a device; the machine may move unexpectedly. Use a wooden stick.

Standing Clear Of Machinery – When troubleshooting a problem with any SLC 500 system, have all personnel remain clear of machinery. The problem may be intermittent, and the machine may move unexpectedly. Have someone ready to operate an emergency stop switch.



CAUTION

POSSIBLE EQUIPMENT OPERATION

Never reach into a machine to actuate a switch. Also, remove all electrical power at the main power disconnect switches before checking electrical connections or inputs/outputs causing machine motion.

Failure to observe these precautions can cause personal injury or equipment damage.

Safety Circuits – Circuits installed on machinery for safety reasons (like over-travel limit switches, stop push-buttons, and interlocks) should always be hard-wired to the master control relay. These circuits should also be wired in series so that when any one circuit opens, the master control relay is de-energized, thereby removing power. Never modify these circuits to defeat their function. Serious injury or equipment damage may result.

Refer to your system's *Installation & Operation Manual* for more information.

Getting Technical Assistance

If you need technical assistance, please review the information in Chapter 5, "Testing Your Module," before calling your local distributor of Spectrum Controls.

Note that your module contains electronic components which are susceptible to damage from electrostatic discharge (ESD). An electrostatic charge can accumulate on the surface of ordinary plastic wrapping or cushioning material. **In the unlikely event that the module should need to be returned to Spectrum Controls, please ensure that the unit is enclosed in approved ESD packaging (such as static-shielding / metallized bag or black conductive container).** Spectrum Controls reserves the right to void the warranty on any unit that is improperly packaged for shipment.

For further information or assistance, please contact your local distributor, or call the Spectrum Controls technical Support at :

USA - 440-646-6900

United Kingdom - 01908 635230

Australia - 800-809-929 or (61) 398-990-335

Brazil - (55) 11 3618 8800

Europe - (49) 2104 960 333

Declaration of Conformity

<i>Declaration of Conformity</i>	
<i>Application of Council Directive(s)</i>	73/23/EEC Low Voltage Directive 89/336/EEC Electromagnetic Compatibility
<i>Standard(s) to which Conformity is Declared</i>	EN50081-2:1993, EN50082-2:1995 EN61010-1:1993, EN61131-2:1995
<i>Manufacturer's Name Manufacturer's Address</i>	Spectrum Controls Inc. 2700 Richards Road South East, Bellevue Washington, 98005 U.S.A.
<i>Importer's Name Importer's Address</i>	Spectrum Controls Inc. 2700 Richards Road South East, Bellevue Washington, 98005 U.S.A.
<i>Type Of Equipment</i>	Allen-Bradley SLC500 Compatible I/O Modules
<i>Model No.</i>	1746sc Series
<i>I, the undersigned, hereby declare that the equipment specified above conforms to the above Directive(s) and Standard(s)</i>	
<i>Date Of Issue:</i> 1/17/97	 (Signature)
<i>Place:</i> Bellevue, Washington U.S.A.	Bruce M. Wanta (Name)
	Chairman (Position)
	SPN: 0300148-02 Rev B.0



The ENCOMPASS logo and SLC 500 are trademarks of Allen-Bradley Company, Inc. Copyright © 2002, 2003, Spectrum Controls, Inc. All rights reserved. Printed in U.S.A. Specifications subject to change without notice.
Publication 0300187-02 Rev. B April 2003

U.S.A. Headquarters
P.O.Box 5533
Bellevue, WA 98006
Fax: (425) 641-9473
Tel: (425) 746-9481

Northeastern U.S.A. Sales Office
48945 Van Dyke, Suite 4B
Utica, MI 48317
Fax: (586) 731-2715
Tel: (586) 731-2397

Southeastern U.S.A. Sales Office
5300 Regency Lake Ct
Sugar Hill, Georgia 30518
Fax: (770) 614-5886
Tel: (770) 614-5885

Web Site: <http://www.spectrumcontrols.com>
E-mail: spectrum@spectrumcontrols.com

